

CHEMICAL PUMPS SINCE 1992

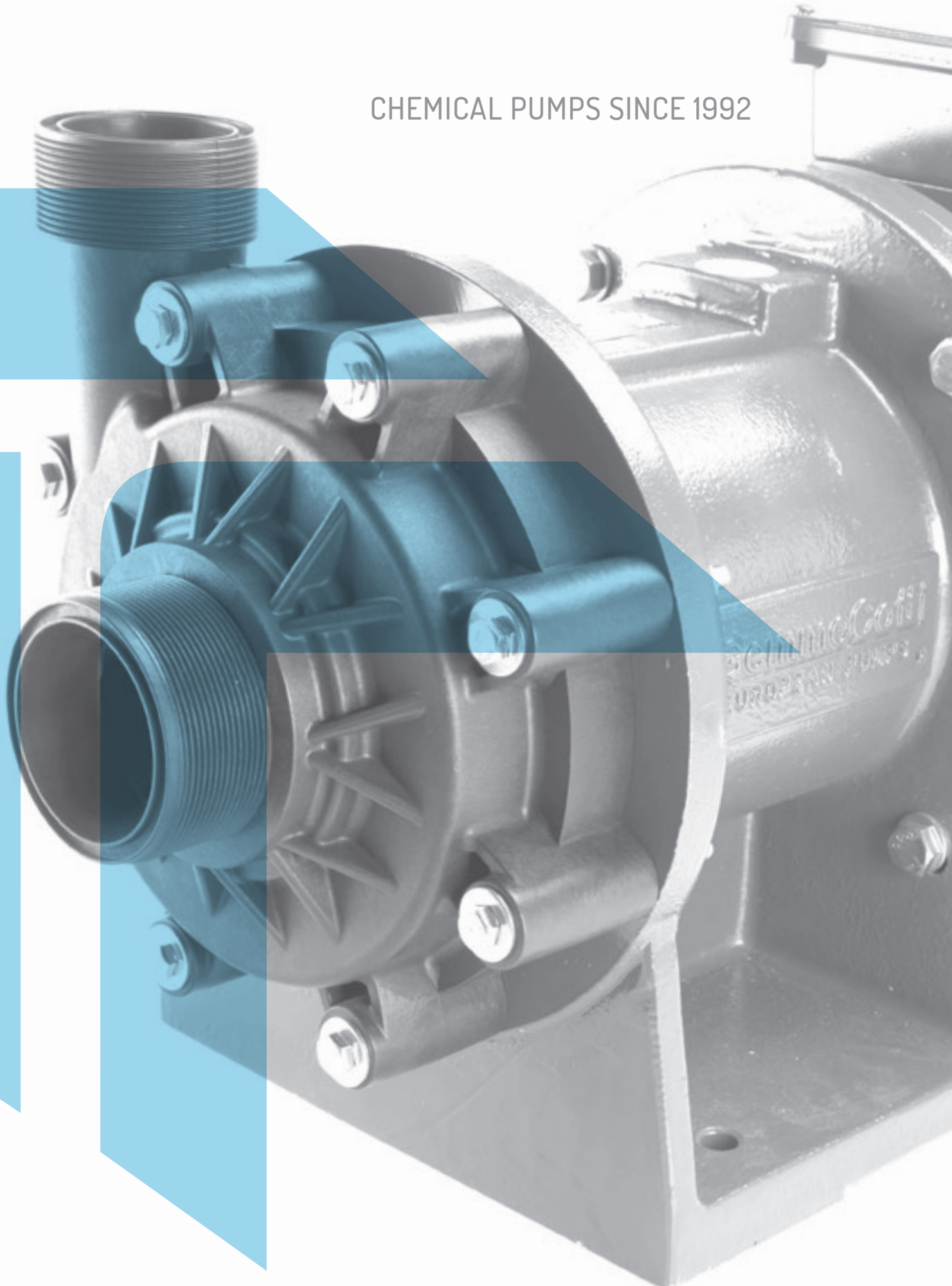

# INDEX



**HTM PP/PVDF**  
PAG. 12



**HCM PP/PVDF**  
PAG. 16



**HTM SS 316**  
PAG. 20



**HTM-SP**  
PAG. 23

NEW



**HTT**  
PAG. 26



**HTT-SP**  
PAG. 28



**HTA**  
PAG. 30

OUR COMPANY / OUR MISSION / OUR VALUES	PAG. 04
SALES AND AFTER-SALES SERVICE / QUALITY MANAGEMENT SYSTEM ISO 9001:2015	PAG. 05
PUMPS PRODUCTION	PAG. 06
PUMPS DESIGN	PAG. 07
MAIN APPLICATIONS	PAG. 08
QUALITY MADE IN ITALY	PAG. 09
MAGNETIC PUMP DESIGN	PAG. 10

1. MAG DRIVE CENTRIFUGAL PUMPS	
INTRODUCTION	PAG. 11
HTM PP/PVDF	PAG. 12
HCM PP/PVDF	PAG. 16
HTM SS 316	PAG. 20
HTM-SP	PAG. 23
2. MAG DRIVE TURBINE PUMPS	
INTRODUCTION	PAG. 25
HTT	PAG. 26
HTT-SP	PAG. 28
HTA	PAG. 30
3. MAG DRIVE ROTARY VANE PUMPS	
INTRODUCTION	PAG. 33
HPP/HPF	PAG. 34
HTP	PAG. 36



**HPP/HPF**  
PAG. 34



**HTP**  
PAG. 36



**HCO**  
PAG. 40



**VPM/VPS/VPL**  
PAG. 43



**HV**  
PAG. 51



**HVL**  
PAG. 53



**HTM-V**  
PAG. 55



**PVA**  
PAG. 56

**4. MECHANICAL SEAL CENTRIFUGAL PUMPS**

INTRODUCTION	PAG. 39
HCO	PAG. 40

**5. LIQUID RING VACUUM PUMPS**

INTRODUCTION	PAG. 42
VPM/VPS/VPL	PAG. 43

**6. VERTICAL PUMPS**

INTRODUCTION	PAG. 50
HV	PAG. 51
HVL	PAG. 53
HTM-V	PAG. 55
PVA	PAG. 56

**7. ATEX PUMPS**

PAG. 58

**8. ACCESSORIES**

PAG. 59

**9. CHEMICAL COMPATIBILITY CHART**

PAG. 62

All the data indicated in this catalogue are pure indicative and can be changed without prior notice.



## OUR COMPANY

GemmeCotti srl has been designing and manufacturing chemical pumps for acids and dangerous liquids since 1992, when its founders started their own company after considerable experience in pump design and production.

Over the years, GemmeCotti has created its own range of industrial pumps designed and manufactured by its experienced team of experts. We are now specialized in magnetic drive pumps, mechanical seal pumps, vertical pumps and vacuum pumps.

GemmeCotti pumps are valued worldwide and they are successfully used in many different industries including: chemical and petrochemical, pharmaceutical, oil refinery, electroplating, printed circuits, electronic, photography, military, water treatments, biotechnology, paper mills, textile, sugar plants, food processing, dairies and many others.

## OUR MISSION

GemmeCotti corporate policy is oriented to quality and continuous improvement. Our main purpose is to become "Privileged supplier" of our customers for chemical pumps for acids and dangerous liquids and to maintain this status. We want to offer the best products and the best service possible with an extremely reduced delivery time.

## OUR VALUES

The values that have guided the company from the beginning are: the quality of the pumps and of their materials, the competence, availability and courtesy of the employees who meet the customer's needs and the constant desire to offer the best service in terms of price/quality and delivery time of the pumps.



“

THE QUALITY  
OF THE PUMPS AND  
OF THEIR MATERIALS.  
THE COMPETENCE,  
AVAILABILITY AND  
COURTESY OF  
THE EMPLOYEES.

”

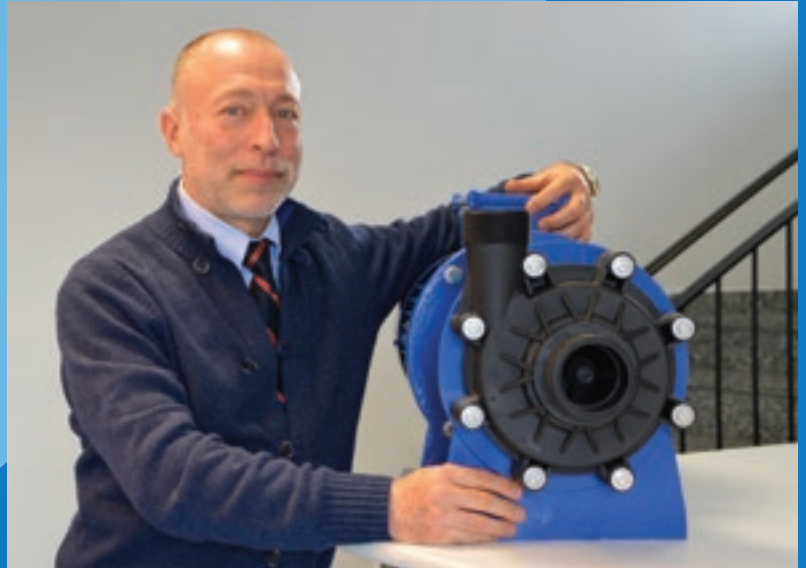

## SALES AND AFTER-SALES SERVICE

GemmeCotti offers to customers a complete sale and after-sale service. Our customer service helps them during the whole sales process, from the pump selection, throughout all the purchasing procedure, as well as technical assistance in case of pump repair and spare-part supply even after the standard warranty period. For every pump supplied there is a complete kit of spare parts available on stock.

## QUALITY MANAGEMENT SYSTEM ISO 9001:2015

“Quality” is a key word for GemmeCotti, this is why we have been an ISO 9001 certified company since 2007. Recently our Quality Management System has been updated to the new ISO 9001:2015, making us one of the first companies in Italy to be certified to the new quality standards. This is a clear proof

of our dedication to constant improvement and desire to offer high quality service and products.

GemmeCotti is constantly becoming more and more efficient and the customer satisfaction is always our priority. Our main desire is to meet the customers' expectations and offer them the best support and top-level products. We aim to continuously improve every business process: from the technical and production department, to the marketing and sales office.

Every aspect has been developed and organized so that the company can be competitive and flexible on the pump market and can maintain the position of leading supplier of chemical pumps.





## PUMPS PRODUCTION

GemmeCotti's first aim is to understand the customers' requirements and supply the best product to fit their needs. The sales and technical office are able to select the right pump model and the recommended materials for the requested application using our company's know-how together with up-to-date software tools. Once chosen, the pump with the selected configuration can be manufactured.

All the parts of the pumps come from qualified Italian suppliers and they are checked and machined carefully by highly skilled GemmeCotti personnel to assure the compliance to the technical constructive drawings. The construction materials of GemmeCotti pumps are of the highest quality and they are suitable to resist corrosion and to handle most of the existing chemicals.

The assembly process takes place in our workshop where inspections are performed step by step on every single pump. When the pumps are ready, we test them one by one using our new and modern test bench to check the performances and the good functioning before shipping them to the customer.

Thanks to a fully stocked warehouse, GemmeCotti can store most of the parts of the standard pumps, so that in case of urgent request, we are able to supply rapidly to the customer both pumps and spare parts.

“

RECENTLY THE COMPANY'S QUALITY SYSTEM HAS BEEN UPDATED TO THE REQUIREMENTS OF THE NEW ISO 9001:2015.

”



## PUMPS DESIGN

GemmeCotti's technical office and research & development department are continuously involved in the design of new pumps and the improvement of the existing ones. Using CAD softwares we make 3D drawings of all the pump parts and pump assembly and then we use finite element method FEM to perform structure analysis in order to assure structural resistance and strength.

All the pumps are designed following four main objectives: have a reliable high-tech design, work and withstand the hardest conditions, be chemically resistant and suitable to operate with corrosive and aggressive liquids, guarantee a long-lasting service with minimum maintenance.

Our engineers are constantly involved in new projects and in the design of new pumps according to what the market of chemical pumps requires and to the customers' needs. We are able to offer more than 400 pump variations for meeting a wide range of applications but, if requested, we can also customize our standard pumps according to the customer's preferences.



## MAIN APPLICATIONS

GemmeCotti supplies a wide range of pump systems and solutions for industrial processes, system builders and OEMs. We combine competence and experience with customization ensuring the perfect solution for specific

industrial applications.

GemmeCotti chemical pumps can be used in many different applications where it is necessary to handle chemicals, acids, dangerous and corrosive liquids.

Among the many industrial fields that use our pumps there are:



CHEMICAL INDUSTRIES



OIL & GAS



PCB INDUSTRIES - PRINTED  
CIRCUIT BOARDS PRODUCTION



AQUARIUMS & MARINE PARKS



FOOD INDUSTRIES



PRODUCTION OF DETERGENTS



WATER TREATMENTS



FILM INDUSTRIES



PHARMACEUTICAL INDUSTRIES



GALVANIC ELECTROPLATING



BIOTECHNOLOGY / BIOFUEL



CAR WASHING PLANTS



BOTTLING COMPANIES  
(BEVERAGES, COSMETICS ETC.)



TEXTILE INDUSTRIES



AIR TREATMENTS



THERMOREGULATION PROCESS



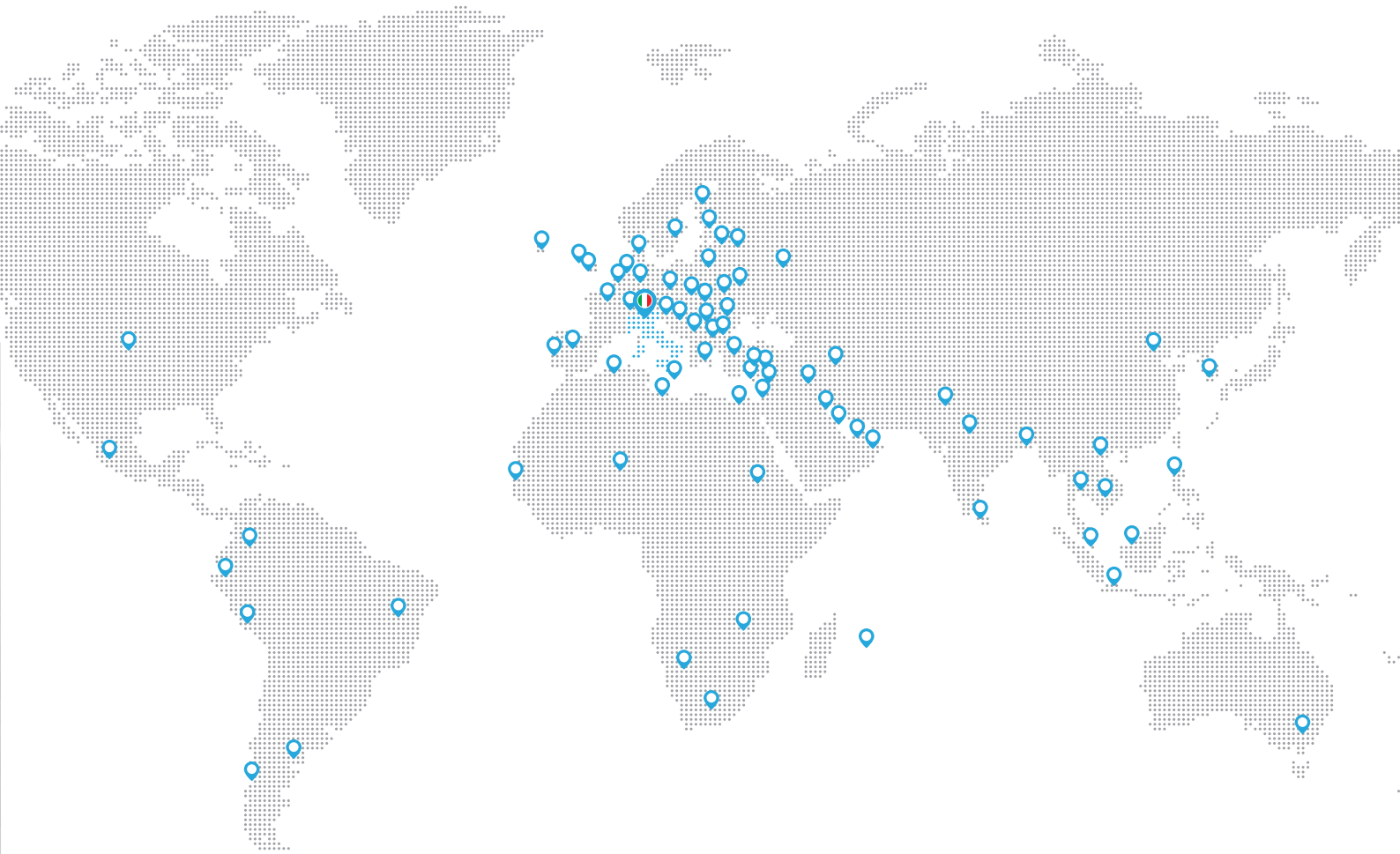

## QUALITY MADE IN ITALY

GemmeCotti pumps are entirely manufactured on our premises and they are 100% MADE IN ITALY. They are designed, assembled and tested in our workshop by highly skilled personnel, while the pump parts are made and machined by our Italian suppliers, who are all located in the area near our company. This is the reason why, for us, the suppliers play an important role in the resulting quality of the pumps. We choose and select them through a strict qualification process and we keep a close relationship with them in order to ensure the highest quality

of each pump part and consequently of the complete pump assembly. The Italian origin has always been considered a guarantee of product quality and value, given by the long experience and technical skills of Italian workers. We are proud to carry on this tradition and to supply top-quality industrial pumps in more than 80 countries around the world. Our customers can count on a product which meets mechanical excellence standards at a competitive price with the assurance of Italian origin.

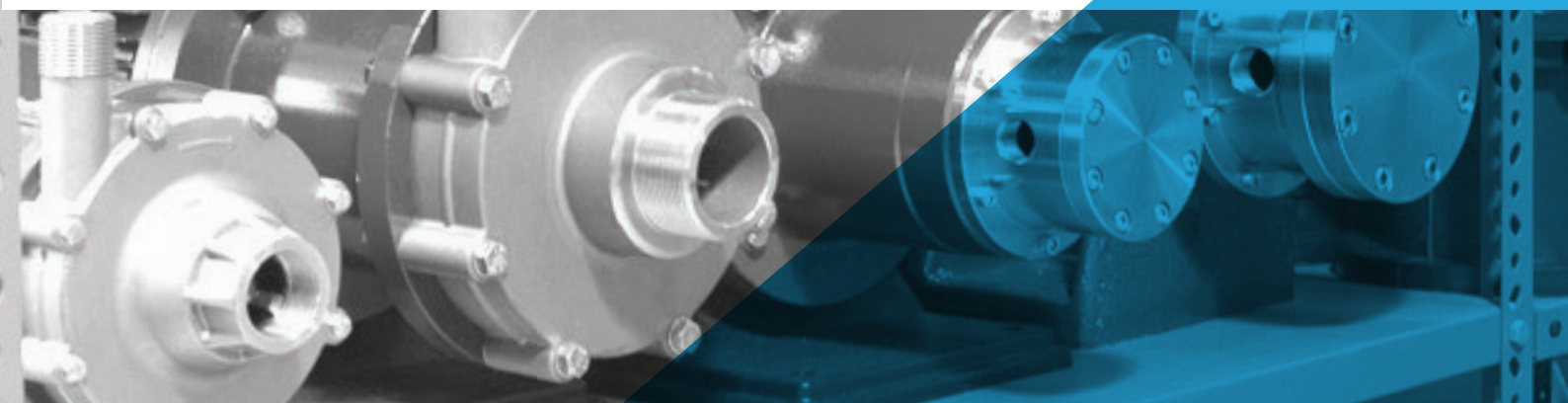

# MAGNETIC PUMP DESIGN

## MAG DRIVE PUMPS

Mag drive pumps have a particular sealless design that is suitable for pumping corrosive and dangerous liquids thanks to the high chemical resistance and absence of leakage and emissions. The structure is really simple and it requires a very reduced maintenance with consequent save in terms of repairing and spare parts costs during the pump life. The external magnet placed on the drive shaft transmits the motion to the internal magnet connected to the impeller which rotates and moves the fluid through the pump.

## ADVANTAGES

1. This special hermetic pump design **prevents any leakage of fluid and fugitive emissions** that, in case of chemicals, corrosive liquids, explosive and flammable fluids, could be very dangerous for people dealing with the pump and for the environment. So mag drive pumps allow to follow strict **environmental and safety objectives** required by many regulations. We shouldn't forget also that some liquids could be very expensive and their loss due to a seal failure may cause high unnecessary extra costs.
2. Mag drive pumps are very **reliable** and **need very low maintenance** thanks to their simple design. With normal working conditions these pumps can work without any kind of repair for more than a decade so their life cost is highly reduced. Nevertheless it's always better to check o-rings and bearings every one/two years just to be sure that there is no wearing.
3. The coupling is very easy because there is **no need for a motor/pump alignment**.

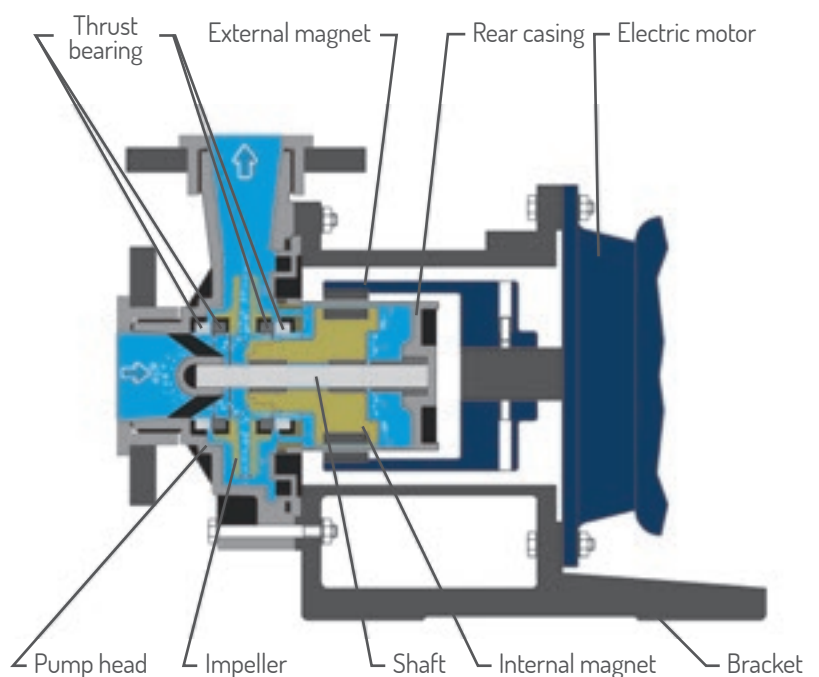

# MAG-DRIVE CENTRIFUGAL PUMPS

## SEAL-LESS MAG DRIVE CENTRIFUGAL PUMPS

In seal-less magnetic drive centrifugal pumps, the external magnet is directly connected to the motor shaft and it transmits the torque to the internal magnet.

The magnetic field created produces a rotation without physical contact between the parts so the impeller spins and moves the fluid. The rear casing is placed between the two magnet joints and it hermetically closes the hydraulic part from the motor.

GemmeCotti can supply three different models of mag drive centrifugal pumps:

### HTM PP/PVDF

- Thermoplastic pumps made in PP or PVDF.
- Capacity up to 45 m<sup>3</sup>/h.
- Head up to 33 mlc.
- Injection molded parts.

### HCM

- Thermoplastic pumps made in PP or PVDF.
- Capacity up to 130 m<sup>3</sup>/h.

- Head up to 48 mlc.
- Pump head machined from a block.

### HTM SS 316

- Metallic pumps made in stainless steel AISI316.
- Capacity up to 32 m<sup>3</sup>/h.
- Head up to: 24 mlc.

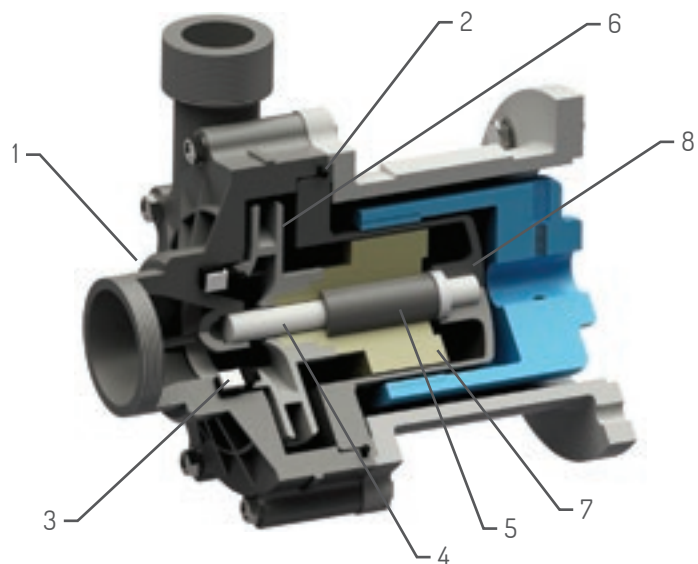

## MATERIALS IN CONTACT WITH THE LIQUID

PART NUMBER - DESCRIPTION	CENTRIFUGAL PUMPS		
	HTM PP/PVDF	HCM	HTM SS 316
1 - PUMP HEAD	PP OR PVDF	PP OR PVDF	AISI 316
2 - O-RING	EPDM OR VITON	EPDM OR VITON	EPDM OR VITON
3 - CASING THRUST BUSH	CERAMIC Al <sub>2</sub> O <sub>3</sub> + EPDM OR VITON	CERAMIC Al <sub>2</sub> O <sub>3</sub> + EPDM OR VITON	PTFEC
4 - SHAFT	CERAMIC Al <sub>2</sub> O <sub>3</sub> 99,7%	CERAMIC Al <sub>2</sub> O <sub>3</sub> 99,7%	HASTELLOY-C 276
5 - BEARINGS	PTFEC	PTFEC	PTFEC
6 - IMPELLER	PP OR PVDF	PP OR PVDF	AISI 316
7 - INTERNAL MAGNET	PP OR PVDF + NdFeB	PP OR PVDF + NdFeB	AISI 316 + SmCo
8 - REAR CASING	PP OR PVDF	PP OR PVDF	AISI 316

## THERMOPLASTIC MAG-DRIVE CENTRIFUGAL PUMPS



### STANDARD:

- Gas threaded In and Out connections.
- Direct starting motor.

### OPTIONAL:

- Flanges available.
- Dry-running protection.
- Baseplate.
- Silicon carbide sleeve bearing.
- HTM pumps are available also for NEMA motors and with NPT connections.

### MAIN FEATURES

Mag drive centrifugal pumps series HTM PP/PVDF are made of thermoplastic materials (Polypropylene and PVDF) and are suitable for high corrosive liquids. Thanks to the innovative mag drive system, pumps model HTM PP/PVDF reduce the risks of leakage and emissions and the maintenance costs.

The transmission of the motion occurs through magnetic joints without any mechanical seal and this design guarantees the maximum safety and efficiency. The pumped liquid has to be clean and without solids in suspension.

- Materials available: PP / PVDF.
- Materials in contact with the liquid; casing and impeller: PP/PVDF; o-ring: EPDM (standard for PP pumps); VITON (standard for PVDF pumps); static shaft: Al203 99,7 %; Bushing PTFEC.
- Max flow: 45 m<sup>3</sup>/h; Max head 33 mlc.
- Temperature: PP: max 70°C – PVDF: max 90°C.
- Max viscosity: 200 cSt.
- Pressure rating: NP 6 at 20°C.
- High torque magnetic coupling NdFeB standard.
- Suitable for high corrosive liquids.

### PERFORMANCE CURVES 50HZ - 2900 RPM

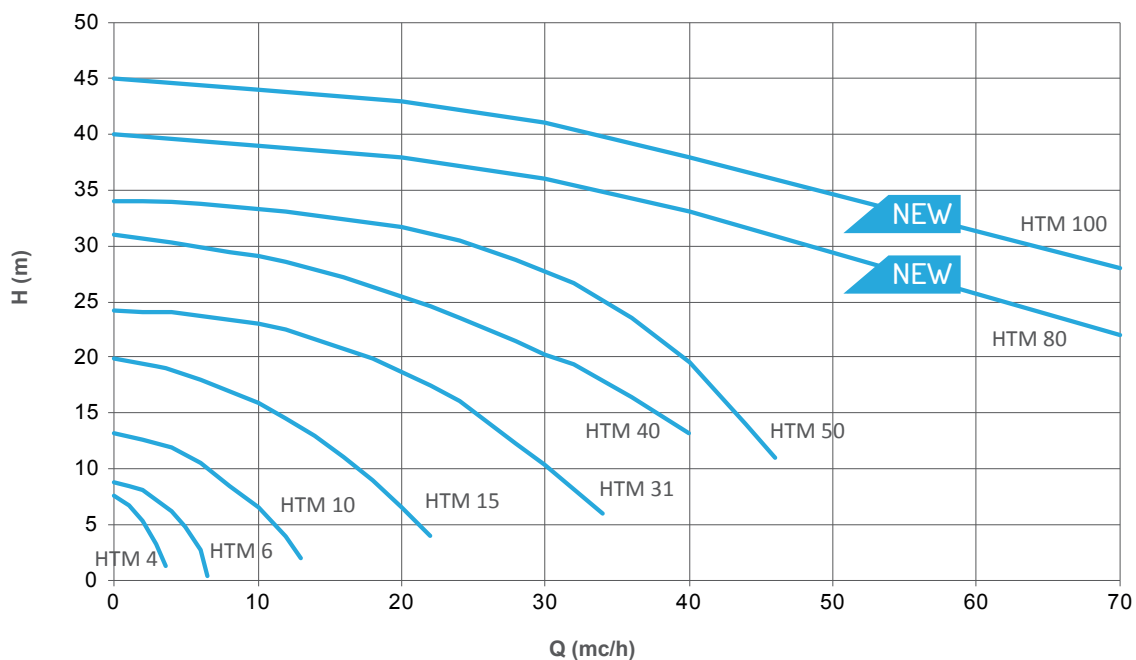

### HTM PP/PVDF TECHNICAL DATA

PUMP SIZE	MATERIAL	Q MAX		H MAX		SUCTION CONNECTION	DISCHARGE CONNECTION	PUMP WEIGHT (KG)		SUITABLE MOTOR POWER (KW) 2900 rpm / FLANGE AND FRAME
		50HZ (M3/H)	60HZ (USGPM)	50HZ (MLC)	60HZ (FT)			PP	PVDF	
HTM 4	PP- PVDF	3,5	16	7	33	1" FEMALE	1/2" MALE	0.9	1	0,12 / 56 B - B3/B5
HTM 6	PP- PVDF	6,5	30	8,5	42	1" FEMALE	3/4" MALE	1.6	1.8	0,25 / 63 B - B3/B5
HTM 10	PP- PVDF	13	68	14	58	1 1/2" FEMALE	1" MALE	2.6	2.9	0,55 / 71 2B - B3/B5 • 1,1 / 80 B - B3/B5
HTM 15	PP- PVDF	23	125	20	90	2" MALE	1 1/2" MALE	5.8	6.6	1,1 / 80 B - B3/B5 • 1,5 / 90 S - B3/B5
HTM 31	PP- PVDF	35	185	24	115	2 1/2" MALE	2" MALE	8.0	8.9	2,2 / 90 L - B3/B5 • 3 / 100 L - B3/B5 • 4 / 112 M - B3/B5
HTM 40	PP- PVDF	42	215	31	150	3" MALE	2 1/2" MALE	19.7	21.3	3 / 100 L - B3/B5 • 4 / 112 M - B3/B5
HTM 50	PP- PVDF	43	220	33	160	3" MALE	2 1/2" MALE	32.2	35	5,5 / 132 S2A - B5 • 7,5 / 132 S2B - B5

### HTM 4-6-10 PP/PVDF DIMENSIONS

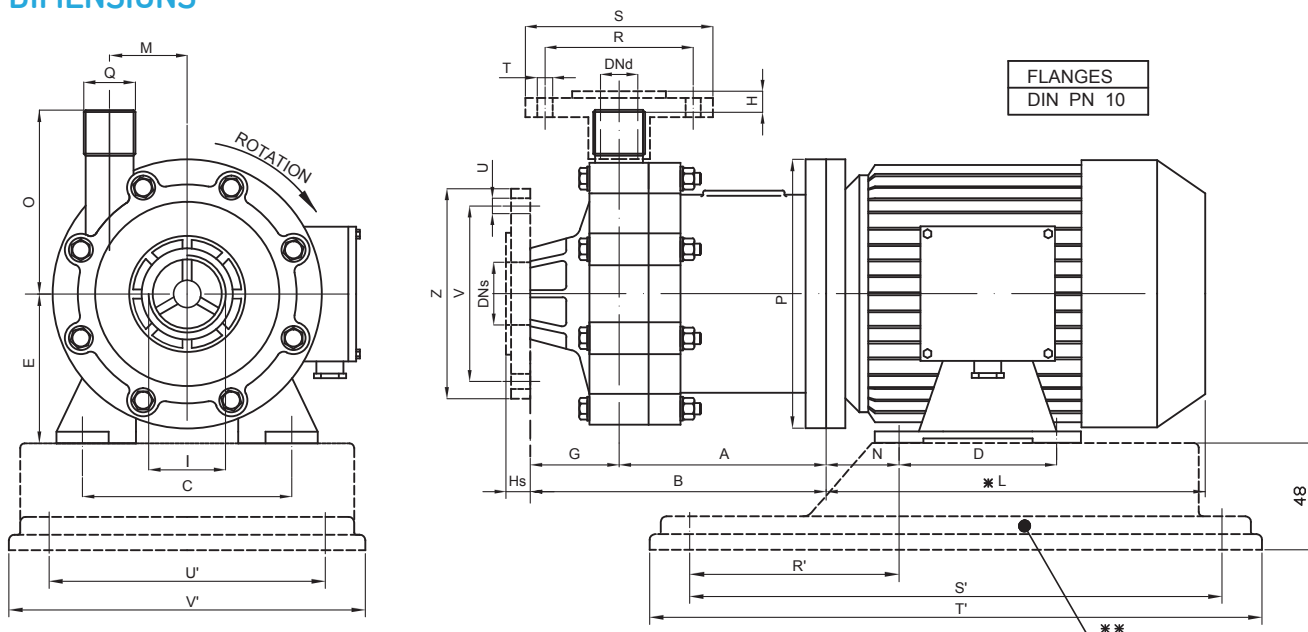

PUMP TYPE	FLANGES DIMENSIONS - mm -							
	R	S	T	U	V	Z	DNs	DNd
HTM 4	-	-	-	-	-	-	-	-
HTM 6	75	105	14	14	85	115	25	20
HTM 10	85	115	14	18	110	150	40	25

PUMP TYPE	MOTOR FLANGE B3 - B5	KW	DIMENSIONS - mm -													BASEPLATE DIMENSIONS - mm -						
			A	B	C	D	E	Hs	G	H	I	L*	M	N	O	P	Q	R'	S'	T'	U'	V'
HTM 4	56 B	0.12	76	115	90	71	56	-	39	-	1" FEMALE	176	34	36	80	120	1/2" MALE	94	244	280	130	160
HTM 6	63 B	0.25	84	143	100	80	63	18	59	6	1" FEMALE	191	45	40	98	140	3/4" MALE	102	244	280	130	160
HTM 10	71 2B	0.55	110	180	112	90	71	20	70	9	1 1/2" FEMALE	215	45	45	100	160	1" MALE	112	244	280	130	160
HTM 10	80B	1.1	122	190	125	100	71	20	70	9	1 1/2" FEMALE	232	45	50	100	200	1" MALE	-	-	-	-	-

\* Different according to the manufacturer. \*\* OPTIONAL UPON REQUEST: Baseplate - Flanges.  
 NOTE: DIRECTION OF ROTATION IS COUNTER CLOCKWISE AS SEEN WHEN FACING THE MOTOR.  
 PUMPS AVAILABLE THREADED OR FLANGED.

## HTM 15-31-40 PP/PVDF DIMENSIONS

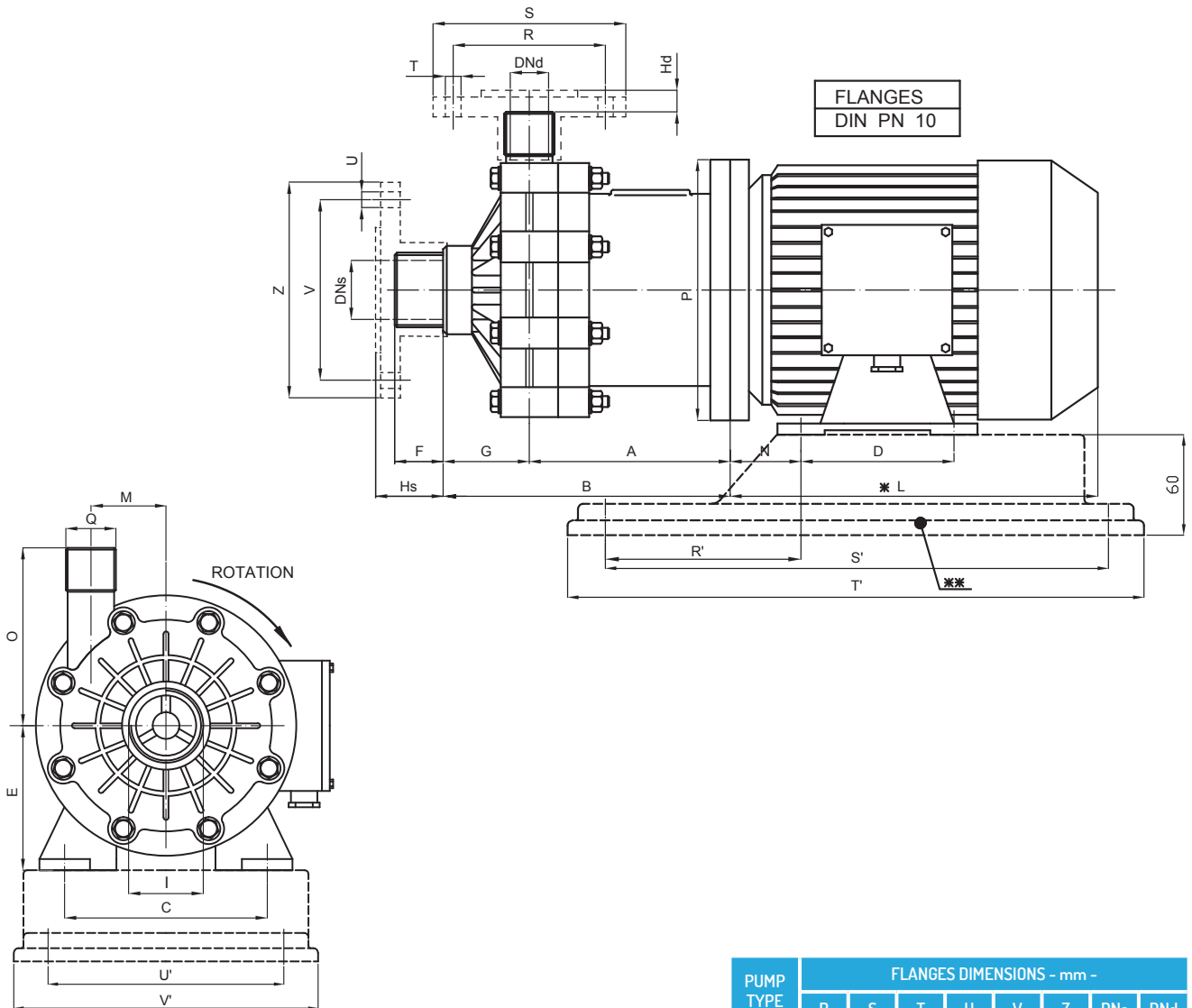

14

PUMP TYPE	FLANGES DIMENSIONS - mm -							
	R	S	T	U	V	Z	DN <sub>s</sub>	DN <sub>d</sub>
HTM 15	110	153	18	18	125	168	50	40
HTM 31	125	168	18	18	145	188	65	50
HTM 40	145	188	18	18	160	203	80	65

PUMP TYPE	MOTOR FLANGE B3 - B5	KW	DIMENSIONS - mm -														BASEPLATE DIMENSIONS - mm -						
			A	B	C	D	E	F	G	H <sub>s</sub>	H <sub>d</sub>	I	L*	M	N	O	P	Q	R'	S'	T'	U'	V'
HTM 15	80 B	1,1	150	230	125	100	80	28	52	42	13	2" MALE	232	66	50	135	200	1-1/2" MALE	120	302	350	157	205
HTM 15	90 S	1,5	160	240	140	100	90	28	52	42	13	2" MALE	256	66	56	135	200	1-1/2" MALE	132	302	350	157	205
HTM 31	90 L	2,2	184	245	140	125	90	30	61	44	13	2 1/2" MALE	280	66	56	140	200	2" MALE	132	302	350	157	205
HTM 31	100 L	3	203	264	160	140	100	30	61	44	13	2 1/2" MALE	315	66	63	140	250	2" MALE	140	352	400	202	250
HTM 31	112 M	4	203	264	190	140	112	30	61	44	13	2 1/2" MALE	325	66	70	140	250	2" MALE	140	352	400	202	250
HTM 40	100 L	3	228	280	160	140	100	40	52	50	10	3" MALE	315	82,5	63	170	250	2 1/2" MALE	140	352	400	202	250
HTM 40	112 M	4	228	280	190	140	112	40	52	50	10	3" MALE	325	82,5	70	170	250	2 1/2" MALE	156	352	400	202	250

\* Different according to the manufacturer. \*\* OPTIONAL UPON REQUEST: Baseplate - Flanges.  
NOTE: DIRECTION OF ROTATION IS COUNTER CLOCKWISE AS SEEN WHEN FACING THE MOTOR.  
PUMPS AVAILABLE THREADED OR FLANGED.

# HTM 50 PP/PVDF DIMENSIONS

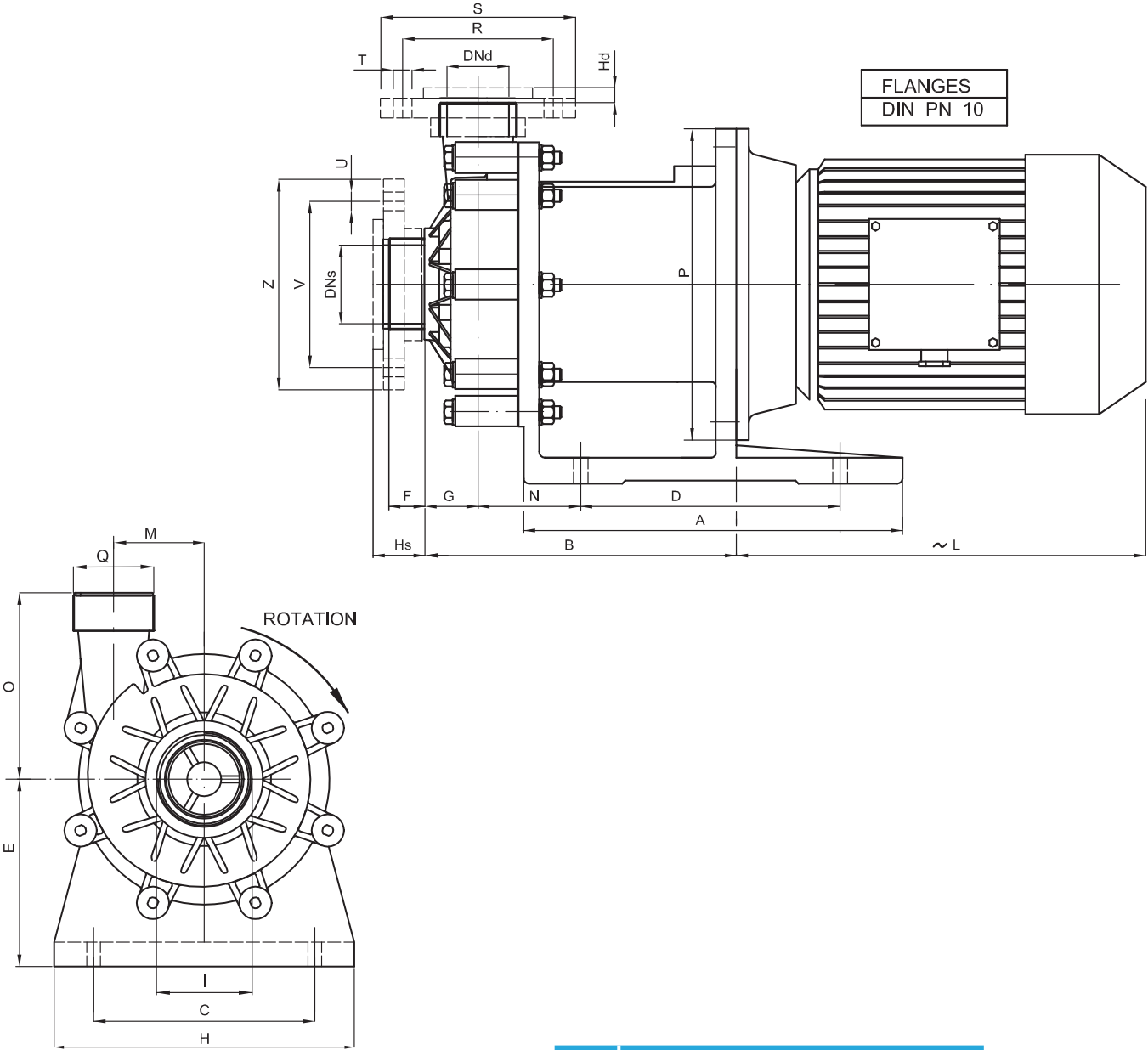

PUMP TYPE	FLANGES DIMENSIONS - mm -							
	R	S	T	U	V	Z	DNs	DNd
HTM 50	145	188	18	18	160	203	80	65

PUMP TYPE	MOTOR FLANGE B3 - B5	KW	DIMENSIONS - mm -																
			A	B	C	D	E	F	G	H	Hs	Hd	I	-L	M	N	O	P	Q
HTM 50	132 S2A	5.5	365	300	216	250	192	40	52	274	50	10	3" MALE	383	82.5	98	170	300	2" 1/2 MALE
HTM 50	132 S2B	7.5	365	300	216	250	192	40	52	274	50	10	3" MALE	421	82.5	98	170	300	2" 1/2 MALE

OPTIONAL UPON REQUEST: Flanges.  
NOTE: DIRECTION OF ROTATION IS COUNTER CLOCKWISE AS SEEN WHEN FACING THE MOTOR.  
PUMPS AVAILABLE THREADED OR FLANGED.

## THERMOPLASTIC MAG-DRIVE CENTRIFUGAL PUMPS

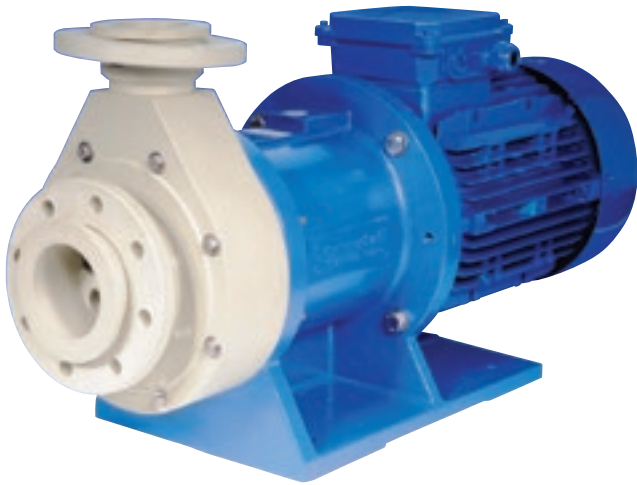

### OPTIONAL:

- Dry-running protection.

### TYPICAL APPLICATIONS:

- High corrosive liquids.
- Toxic, noxious and carcinogenic liquids.

### MAIN FEATURES

Mag drive centrifugal pumps series HCM are made of thermoplastic materials (Polypropylene or PVDF) and, thanks to their strong and resistant structure, they are suitable for high corrosive fluids and heavy duty applications. The pump casing is machined from a solid block for a great resistance in terms of pressure and temperature and the transmission of the motion occurs through magnetic joints without any mechanical seal. This magnetic drive system guarantees the maximum safety and efficiency reducing risks of leakage and emissions.

- Materials available: PP / PVDF.
- Materials in contact with the liquid: pump head and impeller PP or PVDF; o-ring EPDM (standard for PP pumps) VITON (standard for PVDF pumps); shaft Al2O3 99,7%; bushing PTFEC.
- Max capacity: 130 m<sup>3</sup>/h.
- Max head: 48m.
- Max temperature: PP: 70°C -PVDF: 90°C.
- Flanged or threaded connections according to the pump size.
- Strong structure, maximum resistance to corrosive liquids.

### PERFORMANCE CURVES 50HZ - 2900 RPM

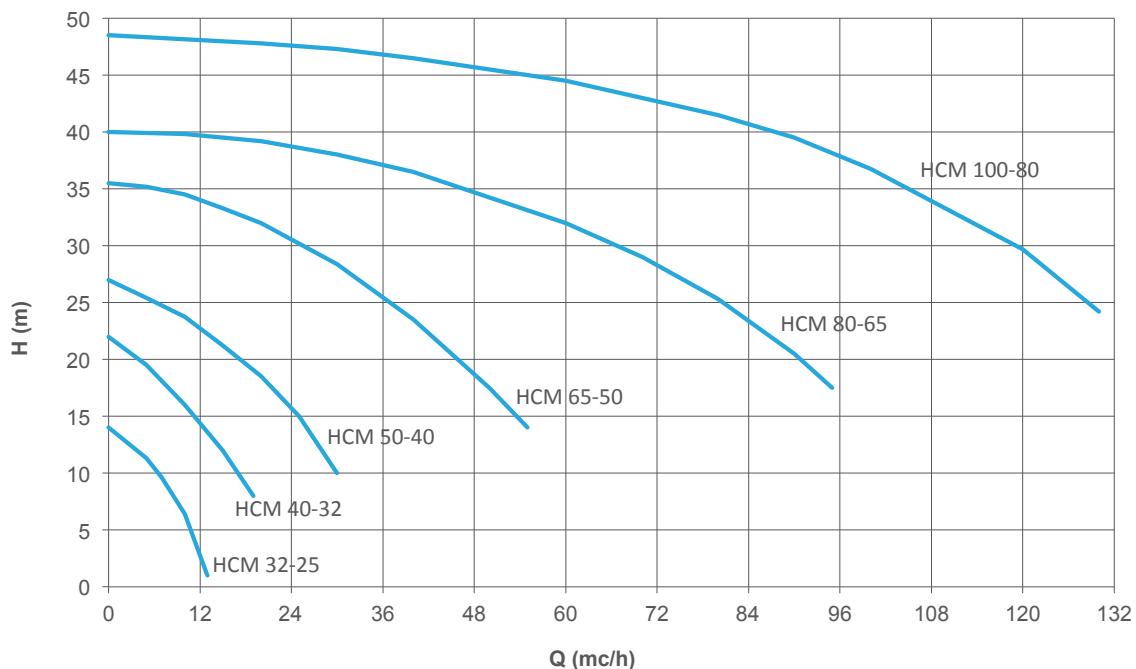



### HCM PP/PVDF TECHNICAL DATA

PUMP SIZE	MATERIAL	Q MAX		H MAX		SUCTION CONNECTION	DISCHARGE CONNECTION	PUMP WEIGHT (KG)		SUITABLE MOTOR POWER (Kw) 2900 rpm / FLANGE AND FRAME
		50HZ (M3/H)	60HZ (USGPM)	50HZ (MLC)	60HZ (FT)			PP	PVDF	
HCM 32-25	PP- PVDF	13	68	14	58	32	25	3	3.5	0,55 / 71 - B3/B5
HCM 40- 32	PP- PVDF	23	125	20	90	40	32	7	8	1,1 / 80 - B3/B5
	PP- PVDF									1,5 / 90 - B3/B5
HCM 50 - 40	PP- PVDF	35	185	24	115	50	40	10	11	2,2 / 90 - B3/B5
	PP- PVDF									3 / 100 - B3/B5
HCM 65- 50	PP- PVDF	43	220	33	165	65	50	37	41	4 / 112 - B3/B5
	PP- PVDF									5,5 / 132 - B5
	PP- PVDF									7,5 / 132 - B5
	PP- PVDF									9 / 132 - B5
HCM 80 - 65	PP- PVDF	92	480	38	180	80	65	55	60	7,5 / 132 S2 - B5
	PP- PVDF									11 / 160 M2A - B5
	PP- PVDF									15 / 160 M2B - B5
	PP- PVDF									18,5 / 160 L2 - B5
HCM 100 - 80	PP- PVDF	135	650	48	197	100	80	60	66	11 / 160 M2A - B5
	PP- PVDF									15 / 160 M2B - B5
	PP- PVDF									18,5 / 160 L2 - B5
	PP- PVDF									22 / 180 M2 - B5

### HCM 32-25 / 40-32 / 50-40 PP/PVDF DIMENSIONS

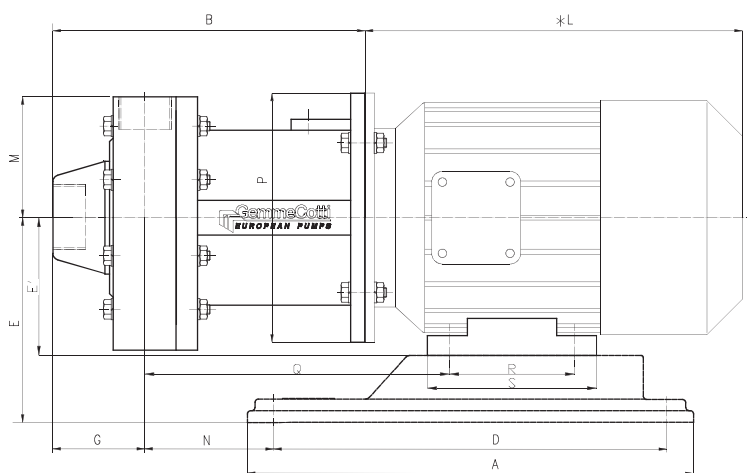
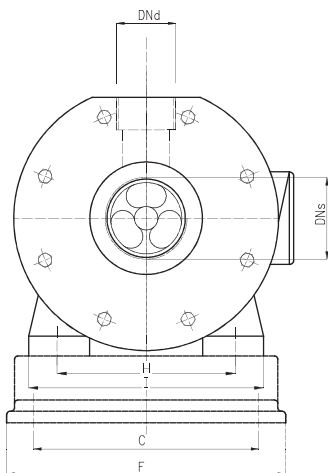

PUMP TYPE	MOTOR FLANGE B3 - B5	Kw	DIMENSIONS - mm -																	CONNECTIONS - in	
			A	B	C	D	E	E'	F	G	H	I	L*	M	N	P	Q	R	S	DN <sub>s</sub>	DN <sub>d</sub>
HCM 32-25	71	0.55	280	180	130	244	119	71	160	65	112	140	260	101	45	158.5	157	90	110	1 1/2" FEMALE	1" FEMALE
HCM 40-32	80	1.1	350	236	146	302	140	80	205	70	125	160	280	142	80	200	200	100	130	1 1/2" FEMALE	1 1/4" FEMALE
	90	1.5		246			150	90			140	170			84		216	100	153		
HCM 50-40	90	2.2	350	268	146	302	150	90	205	84	140	180	280	105	108	200	240	125	160	2" FEMALE	1 1/2" FEMALE
	100	3					400	202			352	160			100		250	160	200		

\* Different according to the manufacturer.  
 OPTIONAL UPON REQUEST: Baseplate - Flanges.

## HCM 32-25 / 40-32 / 50-40 / 65-50L PP/PVDF WITH FLANGES DIMENSIONS

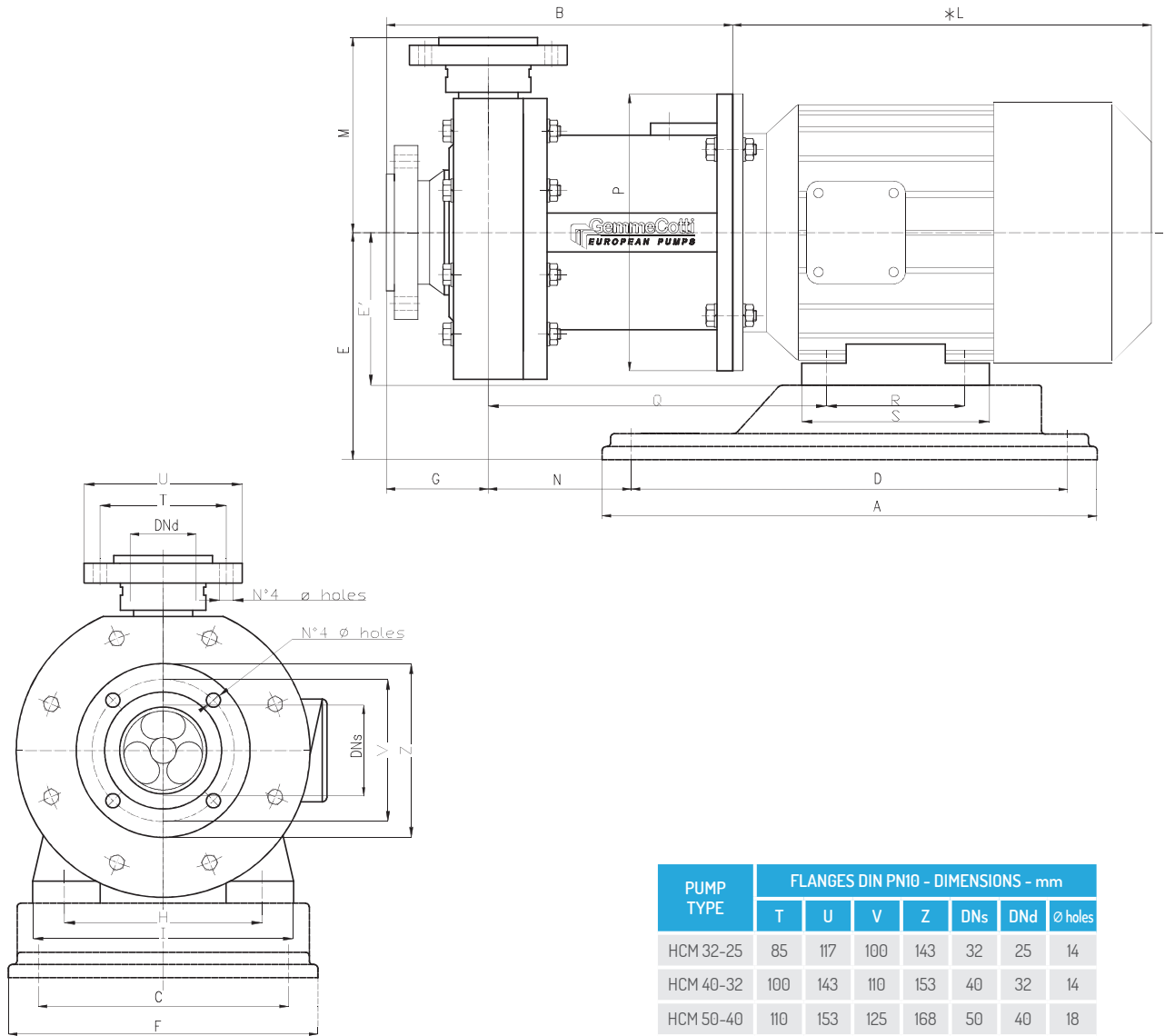

18

PUMP TYPE	FLANGES DIN PN10 - DIMENSIONS - mm						
	T	U	V	Z	DN <sub>f</sub>	DN <sub>d</sub>	∅ holes
HCM 32-25	85	117	100	143	32	25	14
HCM 40-32	100	143	110	153	40	32	14
HCM 50-40	110	153	125	168	50	40	18
HCM 65-50-L	125	168	145	188	65	50	18

PUMP TYPE	MOTOR FLANGE B3 - B5	KW	DIMENSIONS - mm -																
			A	B	C	D	E	E'	F	G	H	I	L*	M	N	P	Q	R	S
HCM 32-25	71	0.55	280	187	130	244	119	71	160	75	112	140	260	115	45	158.5	157	90	110
HCM 40-32	80	1.1	350	236	146	302	140	80	205	85	125	160	280	142	80	200	200	100	130
	90	1.5		246			150	90			140	180					84	216	100
HCM 50-40	90	2.2	350	268	146	302	150	90	205	84	140	180	280	149	108	200	240	125	160
	100	3					400	202			352	160					100	250	160
HCM 65-50-L	112	4	400	331	202	352	172	112	250	103	190	230	324	171	142	250	298	140	195

\* Different according to the manufacturer.



# HTM SS 316

## METALLIC MAG-DRIVE CENTRIFUGAL PUMPS



### MAIN FEATURES

Mag drive centrifugal pumps series HTM SS are made of AISI 316 or, on request, of other metallic materials (such as HASTELLOY or TITANIUM) and are suitable for hydrocarbons, solvents and dangerous liquids. Thanks to the innovative mag drive design, pumps model HTM SS reduce the risks of leakage and emissions and the maintenance costs. The transmission of the motion occurs through magnetic joints without any mechanical seal. This design guarantees the maximum safety and efficiency. The pumped liquid has to be clean and without solids in suspension. Pumps series HTM SS 316 are also available in ATEX version for zone 1 and 2 (pump model EM-C).

### STANDARD:

- Threaded in and out connections.

### OPTIONAL:

- Pump available in other materials (HC 276; Titanium).
- ATEX version (pumps mod. EM-C).
- Explosion proof motor.
- Flanges available.
- Dry-running protection.
- Baseplate.
- Overload switch.

- Materials available: AISI 316;
- Materials in contact with the liquid: casing and impeller: stainless steel AISI 316; o-ring: EPDM/VITON; bushing: PTFE/CARBON; shaft: Hastelloy C276.
- Max flow: 32 m<sup>3</sup>/h; max head: 24 mlc.
- Max temperature: 160° C.
- Max viscosity: 200 cSt.
- Pressure rating: NP 10 at 20° C.

## PERFORMANCE CURVES 50HZ - 2900 RPM

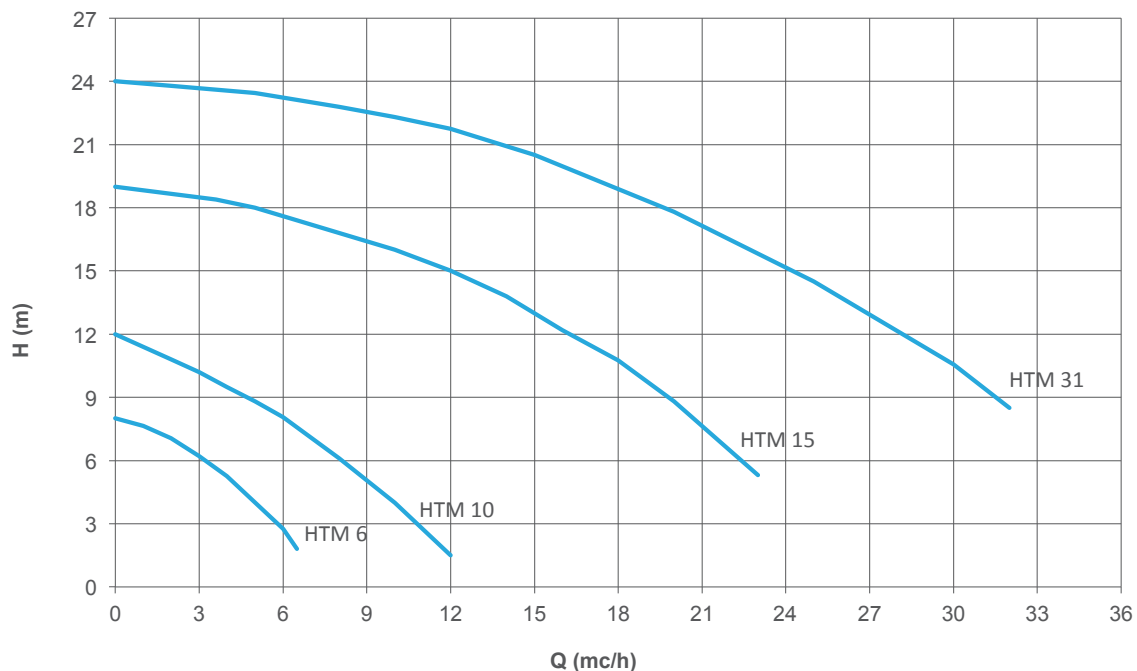

### HTM SS 316 TECHNICAL DATA

PUMP SIZE	MATERIAL	Q MAX		H MAX		SUCTION CONNECTION	DISCHARGE CONNECTION	PUMP WEIGHT (KG)	SUITABLE MOTOR POWER (KW) 2900 rpm / FLANGE AND FRAME
		50HZ (M3/H)	60HZ (USGPM)	50HZ (MLC)	60HZ (FT)				
HTM 6	AISI316	6	30	8	42	1" FEMALE	3/4" MALE	6.2	0,55 / 71 B - B3/B5
HTM 10	AISI316	12	50	12	52	1 1/2" FEMALE	1" MALE	11.7	1,1 / 80 B - B3/B5
HTM 15	AISI316	23	117	19	85	2" MALE	1 1/2" MALE	17	1,5 / 90 S - B3/B5
HTM 31	AISI316	32	180	24	110	2 1/2" MALE	2" MALE	20	2,2 / 90 L - B3/B5

### HTM 6-10 SS316 • EM-C 6-10 SS316 (ATEX VERSION) DIMENSIONS

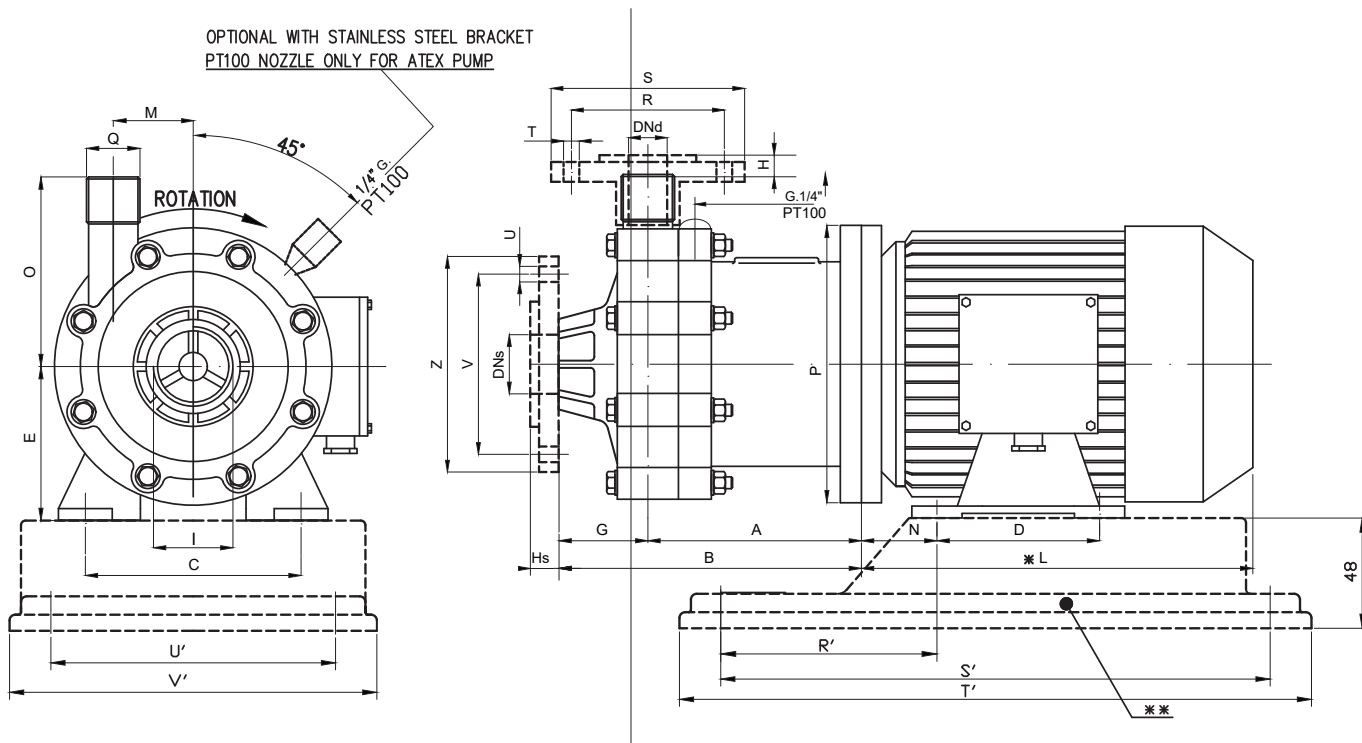

PUMP TYPE	FLANGES DIMENSIONS - mm -							
	R	S	T	U	V	Z	DN <sub>f</sub>	DN <sub>d</sub>
HTM 6 SS316	75	105	14	14	85	115	25	20
HTM 10 SS316	85	115	14	18	110	150	40	25

PUMP TYPE	MOTOR FLANGE B3 - B5	KW	DIMENSIONS - mm -														BASEPLATE DIMENSIONS - mm -					
			A	B	C	D	E	F	G	H	I	L	M	N	O	P	Q	R'	S'	T'	U'	V'
HTM 6 SS316	71 B	0,55	137	194	112	90	71	24	57	4	1" FEMALE	215	46	45	89	160	3/4" MALE	102	244	280	130	160
HTM 10 SS316	80 B	1,1	145	214	125	100	80	20	69	8	1 1/2" FEMALE	232	44	50	98	200	1" MALE	120	302	350	157	205

NOTE: DIRECTION OF ROTATION IS COUNTER CLOCKWISE AS SEEN WHEN FACING THE MOTOR. PUMPS AVAILABLE THREADED OR FLANGED.

## HTM 15-31 SS316 • EM-C 15-31 SS316 (ATEX VERSION) DIMENSIONS

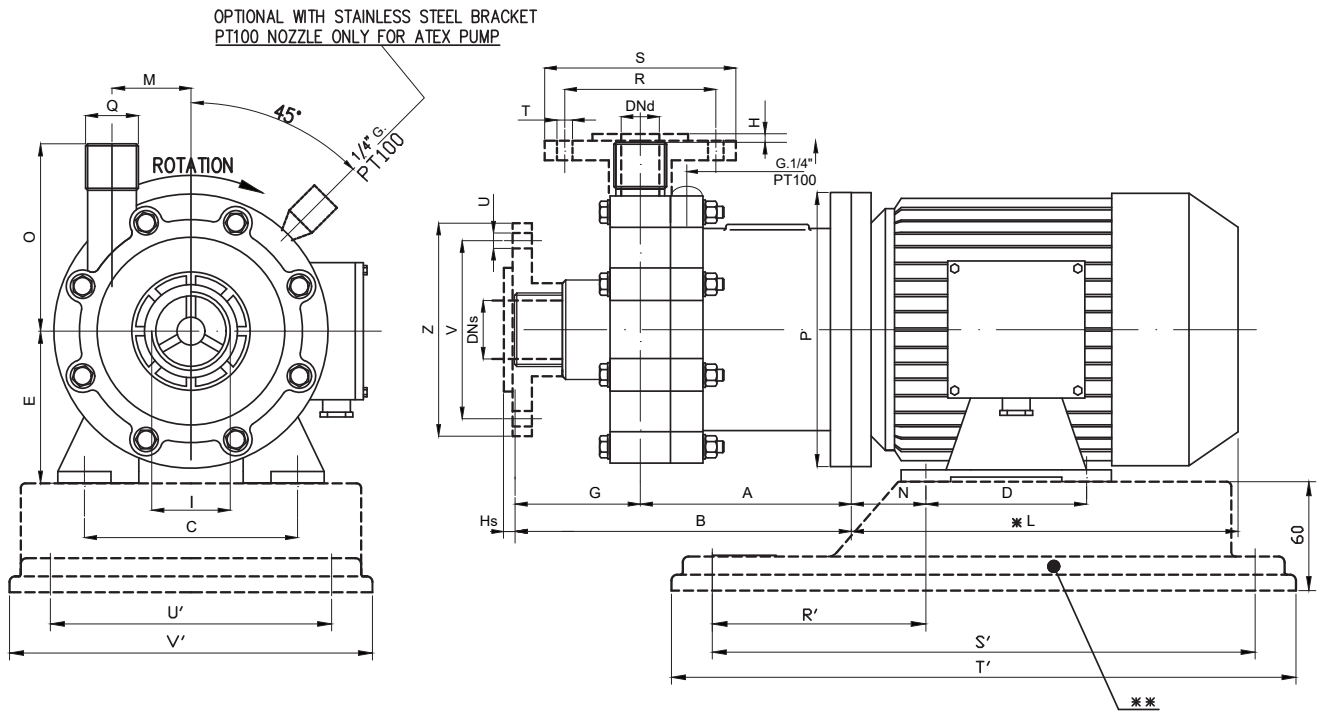

22

PUMP TYPE	FLANGES DIMENSIONS - mm -							
	R	S	T	U	V	Z	DN <sub>s</sub>	DN <sub>d</sub>
HTM 15 SS316	110	153	18	18	125	168	50	40
HTM 31 SS316	125	168	18	18	145	188	65	50

PUMP TYPE	MOTOR FLANGE B3 - B5	KW	DIMENSIONS - mm -														BASEPLATE DIMENSIONS - mm -					
			A	B	C	D	E	H <sub>s</sub>	G	H	I	-L	M	N	O	P	Q	R'	S'	T'	U'	V'
HTM 15 SS316	90 S	1.5	177	257	140	100	90	6	80	4	2" G. MALE	255	66	56	135	200	1" 1/2 G. MALE	132	302	350	157	205
HTM 31 SS316	90 L	2.2	175	266	140	125	90	6.5	91	6	2" 1/2 G. MALE	280	66	56	140	200	2" MALE	132	302	350	157	205

NOTE: DIRECTION OF ROTATION IS COUNTER CLOCKWISE AS SEEN WHEN FACING THE MOTOR.  
PUMPS AVAILABLE THREADED OR FLANGED.

## THERMOPLASTIC SELF-PRIMING MAG DRIVE CENTRIFUGAL PUMPS



### STANDARD:

- Gas threaded In and Out connections.
- Direct starting motor.

### OPTIONAL:

- Flanges DIN or ANSI.
- Baseplate.

### MAIN FEATURES

HTM-SP pumps combine the typical features of our mag drive centrifugal pumps with the self-priming capability. At sea level, these pumps can prime up to 6 meters in a very short time.

HTM-SP pumps can be made of Polypropylene (PP) or PVDF and assure high resistance and chemical compatibility with a large range of corrosive and dangerous fluids.

Thanks to the innovative seal-less magnetic drive system, pumps model HTM-SP guarantee the maximum safety and efficiently reducing risks of leakage and emissions in the environment and the maintenance costs. The pumped liquid has to be clean, without solids in suspension.

- Materials available: PP or PVDF;
- Materials in contact with the liquid:
  - casing and impeller: PP/PVDF;
  - o-ring: EPDM (standard for PP pumps) / VITON (standard for PVDF pumps);
  - static shaft: Al203 99.7%;
  - bearing: PTFEC.
- Capacity up to 26 m<sup>3</sup>/h.
- Head up to 21 m.
- Max temperature: PP: 70° C - PVDF: 90° C.
- Max viscosity: 200 cSt.
- Pressure rating: PN6 at 20° C.
- Self-priming up to 6m at sea level.

## PERFORMANCE CURVES 50HZ - 2900 RPM

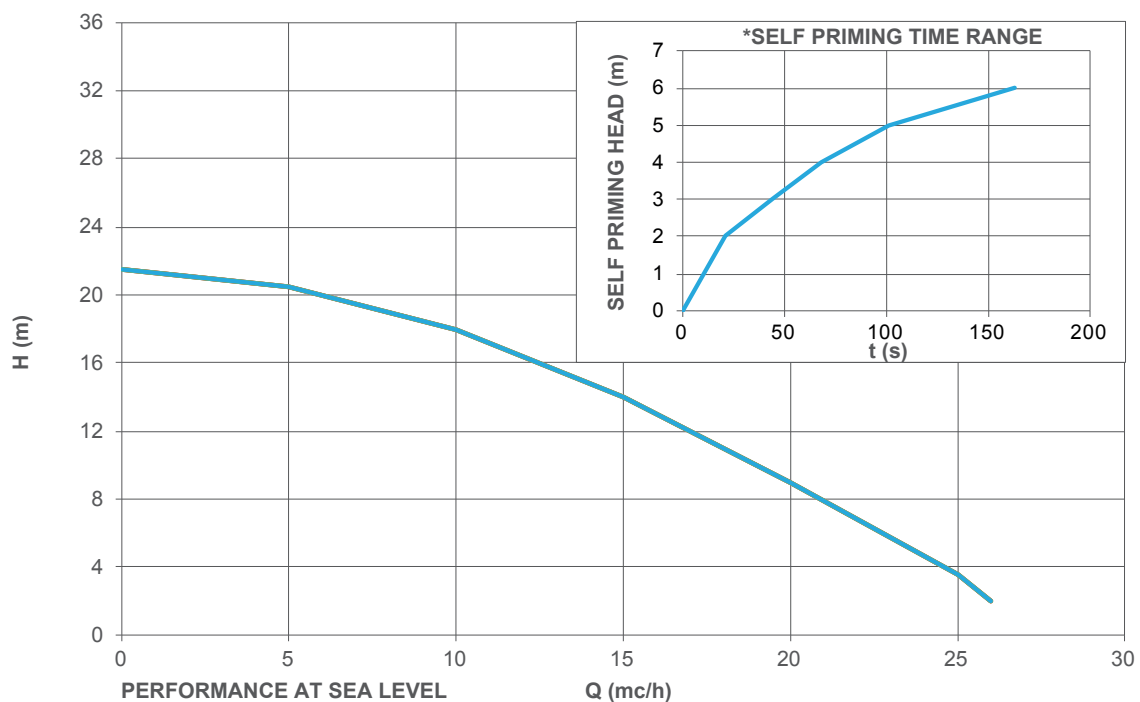

## HTM-SP DIMENSIONS

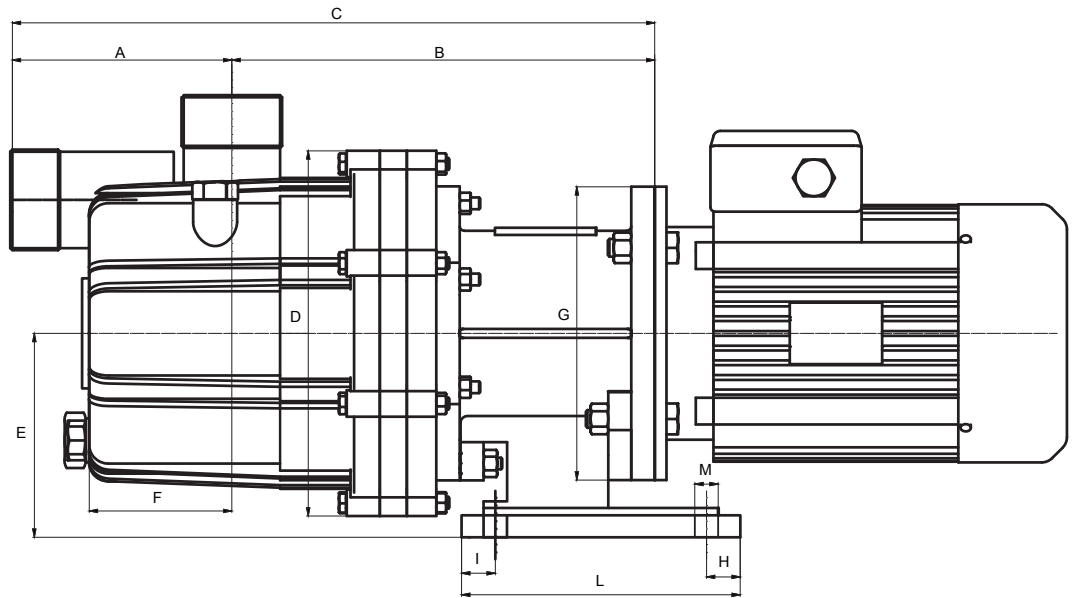

24

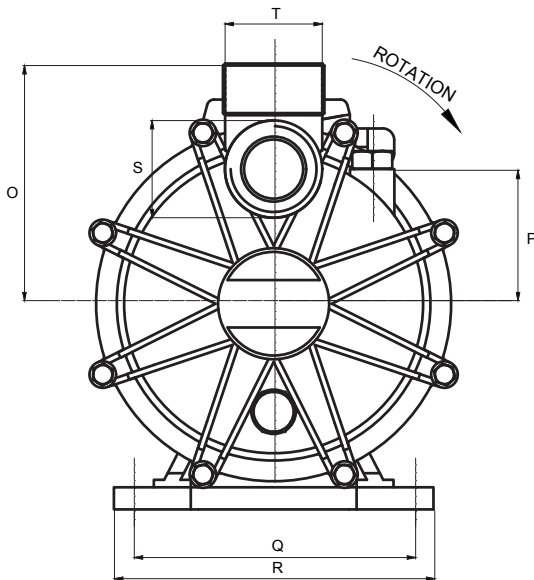

PUMP TYPE	MOTOR FLANGE BS	KW	DIMENSIONS - mm -																
			A	B	C	D	E	F	G	H	I	L	M	O	P	Q	R	S	T
HTM 31 SP	G 90 L	2,2	150	288	438	280	139	97	200	25	25	190	12	161	91	184	216	2" 1/4	2" 1/4
	G 100 L	3	150	308	458	280	139	97	250	25	25	190	12	161	91	184	216	2" 1/4	2" 1/4
	G 112 M	4	150	308	458	280	139	97	250	25	25	190	12	161	91	184	216	2" 1/4	2" 1/4

\* Different according to the manufacturer.

\*\* OPTIONAL UPON REQUEST: Baseplate - Flanges.



# MAG-DRIVE TURBINE PUMPS

## SEAL-LESS MAG DRIVE TURBINE PUMPS

In seal-less magnetic drive turbine pumps, the external magnet is directly connected to the motor shaft and it transmits the torque to the internal magnet.

The magnetic field created produces a rotation without physical contact between the parts and the turbine spins and moves the fluid. The rear casing is placed between the two magnet joints and it hermetically closes the hydraulic part from the motor.

GemmeCotti can supply three different models of mag drive turbine pumps:

### HTT

- Thermoplastic pumps made in PP or PVDF.
- Capacity up to 9 m<sup>3</sup>/h.
- Head up to 50 mlc.

### HTT-SP

- Thermoplastic pumps made in PP or PVDF.
- Capacity up to 7 m<sup>3</sup>/h.
- Head up to 25 mlc.

- Machined from a block.
- Self-priming up to 3 m.

### HTA

- Metallic pumps made in stainless steel AISI316.
- Capacity up to 7 m<sup>3</sup>/h.
- Head up to: 80 mlc.

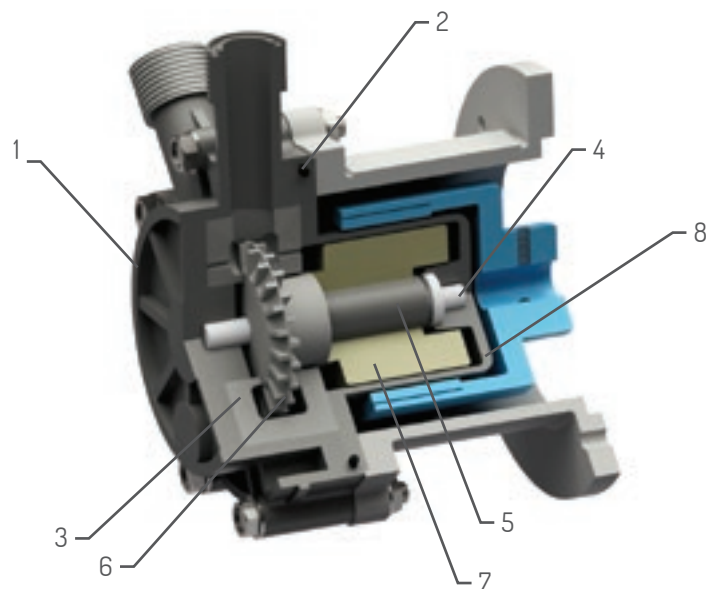

## MATERIALS IN CONTACT WITH THE LIQUID

PART NUMBER - DESCRIPTION	TURBINE PUMPS		
	HTT	HTT-SP	HTA
1 - PUMP HEAD	PP OR PVDF	PP OR PVDF	AISI 316
2 - O-RING	EPDM OR VITON	EPDM OR VITON	EPDM OR VITON
3 - FRONT AND REAR DISC	PP OR PVDF	PP OR PVDF	PTFEC
4 - SHAFT + RING	CERAMIC Al <sub>2</sub> O <sub>3</sub> 99,7%	CERAMIC Al <sub>2</sub> O <sub>3</sub> 99,7%	HASTELLOY-C 276
5 - BEARING	PTFEC	PTFEC	PTFEC
6 - IMPELLER	PVDF	PVDF	AISI 316
7 - INTERNAL MAGNET	PP OR PVDF + NdFeB	PP OR PVDF + NdFeB	AISI 316 + SmCo
8 - REAR CASING	PP OR PVDF	PP OR PVDF	AISI 316

## THERMOPLASTIC MAG-DRIVE REGENERATIVE TURBINE PUMPS



### STANDARD:

- Gas threaded In and Out connections.
- Static shaft in high purity ceramic.
- Chemical resistant PTFE/carbon sleeve bearings.
- High torque magnetic coupling.
- Direct starting motor.

### OPTIONAL:

- DIN or ANSI 150 flanges available.
- Baseplate.
- Dry-running protection.

Mag drive regenerative turbine pumps series HTT are made of thermoplastic materials (polypropylene-PP and PVDF) and are suitable for pumping high corrosive liquids. Thanks to the innovative mag drive system, pumps model HTT reduce risks of leakage and emissions and the maintenance costs. The transmission of the motion occurs through magnetic joints without any mechanical seal. This sealless design guarantees the maximum safety and efficiency. The pumped liquid has to be clean and without solids in suspension.

### MAIN FEATURES

- Materials available: PP / PVDF.
- Plastic injection moulded
- Materials in contact with the liquid: casing and rear casing: PP/PVDF; Impeller: PVDF; o-ring: EPDM (standard for PP pumps); VITON (standard for PVDF pumps); shaft: Al203 99,7%; bearing: PTFEC.
- Max flow: 9 m<sup>3</sup>/h; Max head 50 mlc.
- Temperature: PP: max 70°C – PVDF: max 90°C.
- Max viscosity: 40 cPs.
- Pressure rating: NP 6.
- It handles up to 20% entrained gas.  
HTT pump resists cavitation.

## PERFORMANCE CURVES 50HZ - 2900 RPM

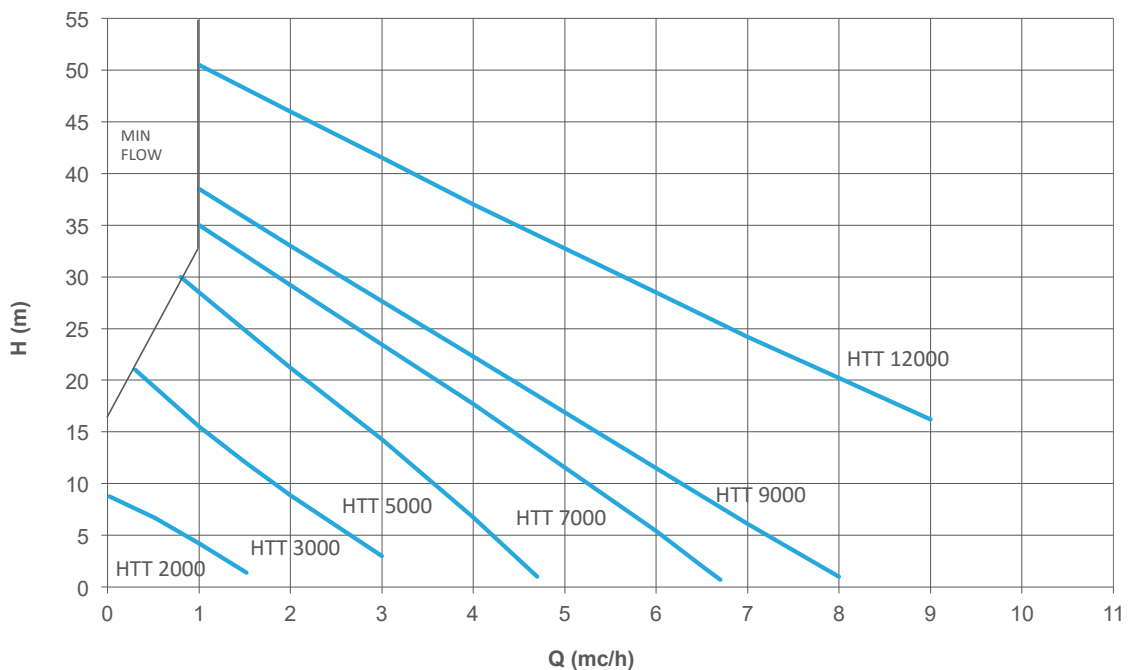

### HTT TECHNICAL DATA

PUMP SIZE	MATERIAL	Q MAX		H MAX		SUCTION CONNECTION	DISCHARGE CONNECTION	PUMP WEIGHT (KG)		SUITABLE MOTOR POWER (Kw) - 2900 rpm	MOTOR FLANGE AND FRAME
		50HZ (M3/H)	60HZ (USGPM)	50HZ (MLC)	60HZ (FT)			PP	PVDF		
HTT 2000	PP- PVDF	1.7	8.8	10	50	1" MALE	1" MALE	2.8	3.8	0,37	71 - B3/B5
HTT 3000	PP- PVDF	3	15	21	102	1" MALE	1" MALE	2.8	3.8	0,37	71 - B3/B5
										0,55	71 - B3/B5
HTT 5000	PP- PVDF	5	26	30	140	1 1/2" MALE	1 1/2" MALE	8	10	0,75	80 - B3/B5
										1,1	80 - B3/B5
HTT 7000	PP- PVDF	7	37	36	162	1 1/2" MALE	1 1/2" MALE	8	10	1,1	80 - B3/B5
										1,5	90 S - B3/B5
										2,2	90 L - B3/B5
HTT 9000	PP- PVDF	8	41	36	177	1 1/2" MALE	1 1/2" MALE	8	10	2,2	90 - B3/B5
										3	100 - B3/B5
HTT 12000	PP- PVDF	9	42	48	235	1 1/2" MALE	1 1/2" MALE	8	10	3	100 - B3/B5
										4	112 - B3/B5

### HTT 2000 - 3000 - 5000 - 7000 - 9000 - 12000 PP/PVDF DIMENSIONS

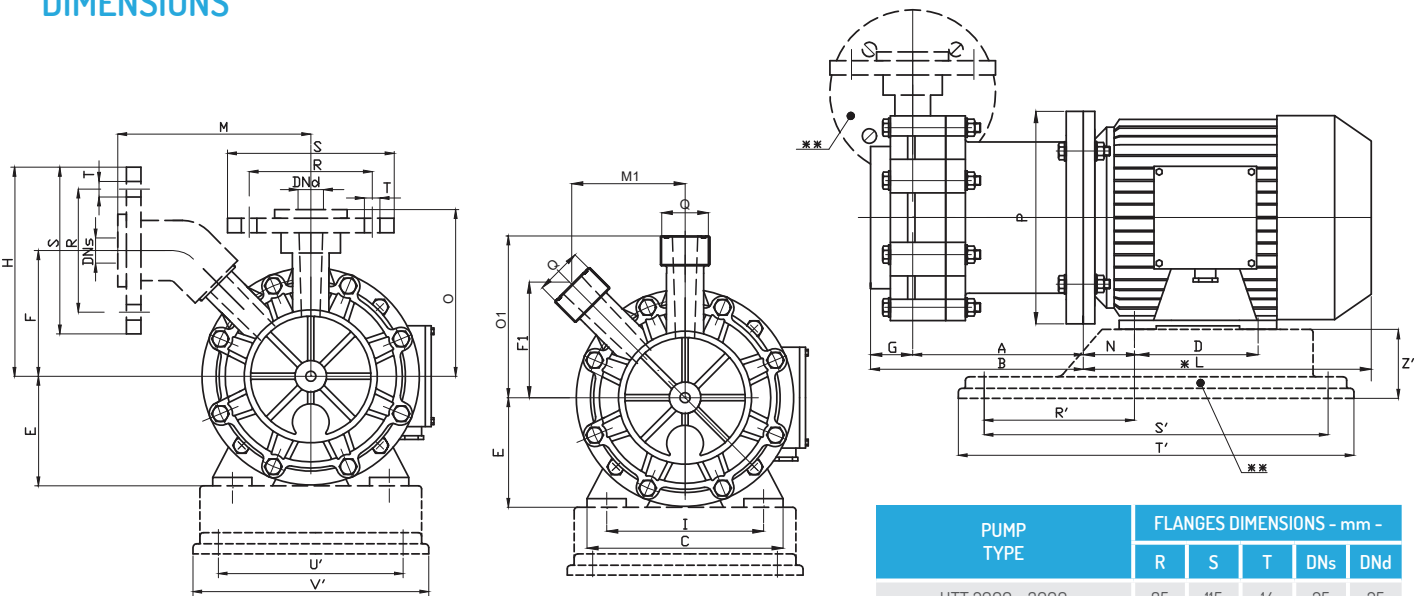

PUMP TYPE	FLANGES DIMENSIONS - mm -				
	R	S	T	DN <sub>s</sub>	DN <sub>d</sub>
HTT 2000 - 3000	85	115	14	25	25
HTT 5000 - 7000 - 9000 - 12000	110	153	18	40	40

PUMP TYPE	MOTOR FLANGE B3 - B5	Kw	DIMENSIONS - mm -																BASEPLATE DIMENSIONS - mm -							
			A	B	C	D	E	F	F1	G	H	I	*L	M	M1	N	O	O1	P	Q	R'	S'	T'	U'	V'	Z'
HTT 2000	71 A	0.37	118	146	142	90	71	86	78	28	145	112	192	135	78	45	116	110	160	1" MALE	112	244	280	130	160	48
	71 B	0.55	118	146	142	90	71	86	78	28	145	112	215	135	78	45	116	110	160	1" MALE	112	244	280	130	160	48
HTT 5000	80 A	0.75	187	221	160	100	80	110	95	34	187	125	215	189	95.5	50	148	135	200	1 1/2" G MALE	120	302	350	157	205	60
	80 B	1.1	187	221	160	100	80	110	95	34	187	125	232	189	95.5	50	148	135	200	1 1/2" G MALE	120	302	350	157	205	60
HTT 7000	90 S	1.5	187	221	170	100	90	110	95	34	187	140	255	189	95.5	56	148	135	200	1 1/2" G MALE	120	302	350	157	205	60
	90 L	2.2	187	221	170	125	90	110	95	34	187	140	280	189	95.5	56	148	135	200	1 1/2" G MALE	132	302	350	157	205	60
HTT 9000	100	3	207	241	200	140	100	110	95	34	187	160	315	189	95.5	63	148	135	250	1 1/2" G MALE	140	352	400	202	250	60
	100 L	3	207	241	200	140	100	110	95	34	187	160	315	189	95.5	63	148	135	250	1 1/2" G MALE	140	352	400	202	250	60
HTT 12000	G 112 M	4	207	241	230	140	112	110	95	34	187	190	324	189	95.5	70	148	135	250	1 1/2" G MALE	156	352	400	202	250	60

\* Different according to the manufacturer. \*\* OPTIONAL UPON REQUEST: Baseplate - Flanges.  
 NOTE: DIRECTION OF ROTATION IS COUNTER CLOCKWISE AS SEEN WHEN FACING THE MOTOR.  
 PUMPS AVAILABLE THREADED OR FLANGED.

## THERMOPLASTIC MAG-DRIVE REGENERATIVE TURBINE PUMPS, SELF-PRIMING



### STANDARD:

- High torque magnetic coupling.
- Chemical resistant PTFE/carbon sleeve bearings.
- Static shaft in high purity ceramic.
- Direct starting motors.

### OPTIONAL:

- ANSI 150 flanges available.
- Baseplate.

HTT-SP pumps can prime up to 5 m with water at ambient temperature. The casing is made from a PP solid machined block and the impeller in PVDF for maximum chemical resistance. The casing is machined from a solid block. The impeller in PVDF is self-balanced to eliminate thrust bearing wear and it is separate to minimize the maintenance costs. This kind of pump offers maximum resistance withstanding also external corrosion. It handles up to 20% entrained gas and resists cavitation.

### MAIN FEATURES:

- Max flow: 6 m<sup>3</sup>/h; max head 28 m.
- Max temperature: PP: 70°C - PVDF: 90°C.
- High torque magnetic coupling.
- Chemical resistant PTFE/carbon sleeve bearings.
- Static shaft in high purity ceramic.
- Direct starting motor.

## PERFORMANCE CURVES 50HZ - 2900 RPM

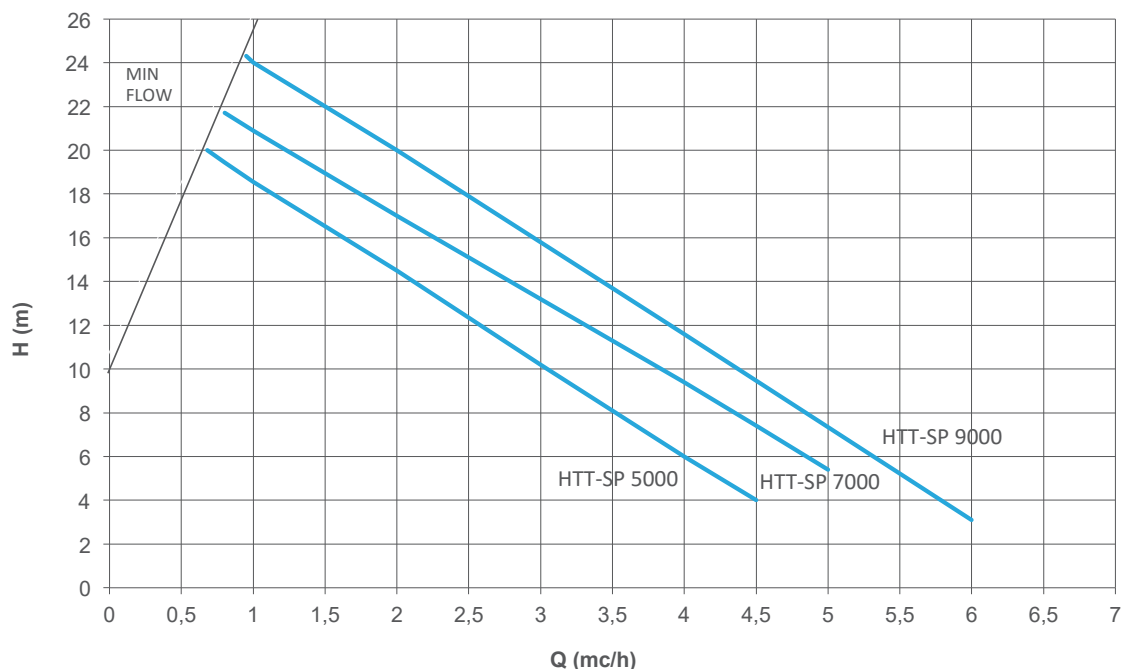

### HTT-SP TECHNICAL DATA

PUMP SIZE	MATERIAL	Q MAX		H MAX		SUCTION CONNECTION	DISCHARGE CONNECTION	SUITABLE MOTOR POWER (KW) - 2900 rpm	MOTOR FLANGE AND FRAME
		50HZ (M3/H)	60HZ (USGPM)	50HZ (MLC)	60HZ (FT)				
HTT-SP 5000	PP- PVDF	4.5	23	18	90	1" FEMALE	1" FEMALE	0,75	80 - B3/B5
								1,1	80 - B3/B5
HTT-SP 7000	PP- PVDF	5	27	20	98	1" FEMALE	1" FEMALE	1,1	80 - B3/B5
								1,5	90 S - B3/B5
HTT-SP 9000	PP- PVDF	6	32	24	110	1" FEMALE	1" FEMALE	2,2	90 L - B3/B5
								3	90 - B3/B5

### HTT-SP DIMENSIONS

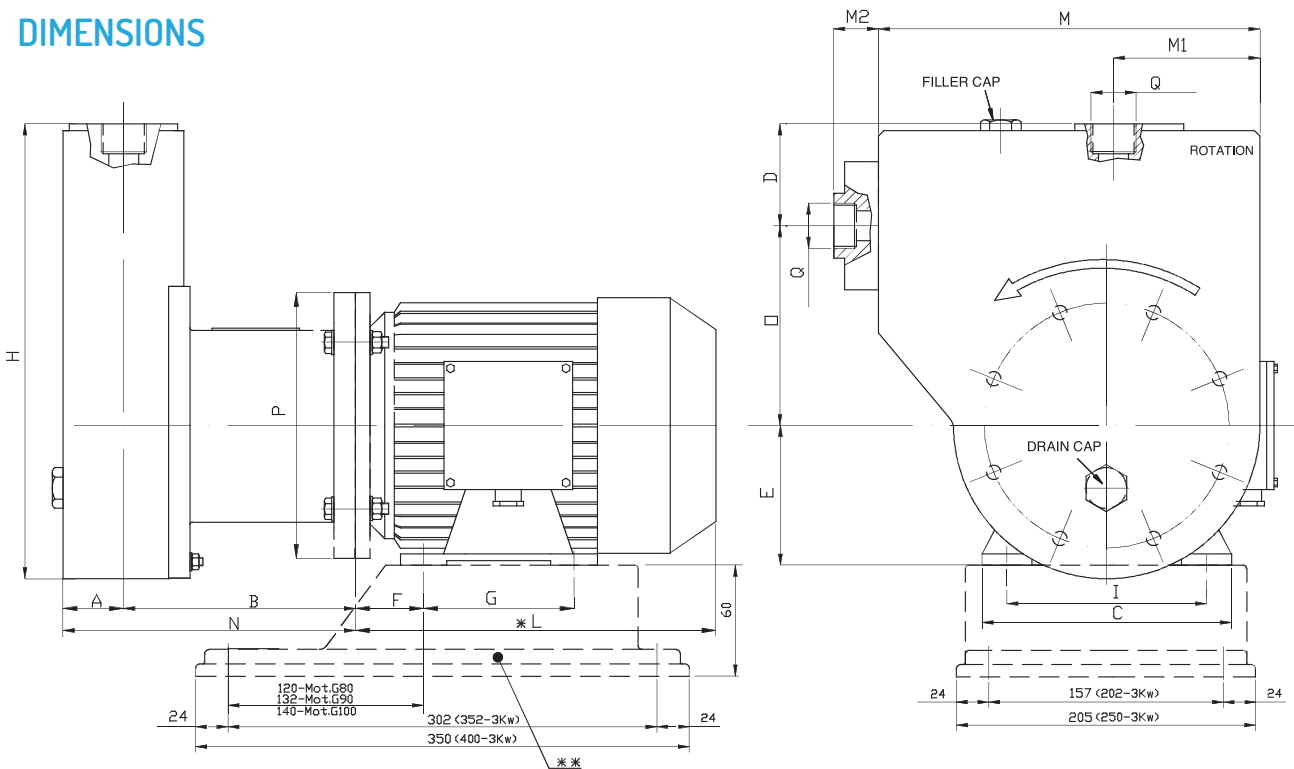

PUMP TYPE	MOTOR FLANGE B3 - B5	KW	DIMENSIONS - mm -																
			A	B	C	D	E	F	G	H	I	*L	M	M1	M2	N	O	P	Q
HTT-SP 5000	80	0,75	PP = 45 PVDF = 41	175	160	70	80	50	100	325	125	215	270	97,5	33	PP = 220 PVDF = 216	147	200	1" FEMALE
		232																	
HTT-SP 7000	80	1,1	PP = 45 PVDF = 41	175	160	70	80	50	100	325	125	232	270	97,5	33	PP = 220 PVDF = 216	147	200	1" FEMALE
		255																	
HTT-SP 9000	90	1,5	PP = 45 PVDF = 41	175	170	70	90	56	125	325	140	280	270	97,5	33	PP = 220 PVDF = 216	147	200	1" FEMALE
		280																	
HTT-SP 9000	90	2,2	PP = 45 PVDF = 41	175	170	70	90	56	125	325	140	280	270	97,5	33	PP = 220 PVDF = 216	147	200	1" FEMALE
		340										250							
HTT-SP 9000	100	3	PP = 45 PVDF = 41	175	200	70	100	63	140	325	160	340	270	97,5	33	PP = 220 PVDF = 216	147	250	1" FEMALE
		340										250							

\* Different according to the manufacturer.

\*\* OPTIONAL UPON REQUEST: Baseplate - Flanges.

## METALLIC MAG-DRIVE REGENERATIVE TURBINE PUMPS



### STANDARD

- Static shaft in HC 276.
- Chemical resistant PTFE/Carbon sleeve bearings standard.
- High torque magnetic coupling.
- Direct starting motors.

### OPTIONAL

- ANSI 300 flanges available.
- ATEX version (pump mod. EM-T).
- Explosion proof motor.
- Dry-running protection.
- Baseplate.

### MAIN FEATURES

Mag drive regenerative turbine pumps series HTA are made of AISI 316 or, if requested, of other metallic materials (HASTELLOY or TITANIUM) and are suitable for solvents, hydrocarbons, dangerous and inflammable liquids. Thanks to the innovative mag drive system, pumps model HTA reduce the risks of leakage and emissions and maintenance costs. The transmission of the motion occurs through magnetic joints without any mechanical seal. This design guarantees the maximum hermetic safety and efficiency. The pumped liquid has to be clean and without solids in suspension.

Pumps series HTA are also available in ATEX version for zone 1 and 2 (pump model EM-T).

- High head / low flow capability minimizes by-pass requirements.
- Materials available: AISI 316;
- Materials in contact with the liquid: casing and impeller: stainless steel AISI 316; o-ring EPDM/VITON; bushing: PTFEC; shaft: Hastelloy C276.
- Max flow 7 m<sup>3</sup>/h; max head 80 m.
- Max Temperature: 160°C.
- Pressure Rating NP 25 at 20°C.
- Impeller design handles up to 20% entrained gas. Ideal for pumping liquefied gas.

## PERFORMANCE CURVES 50HZ - 2900 RPM

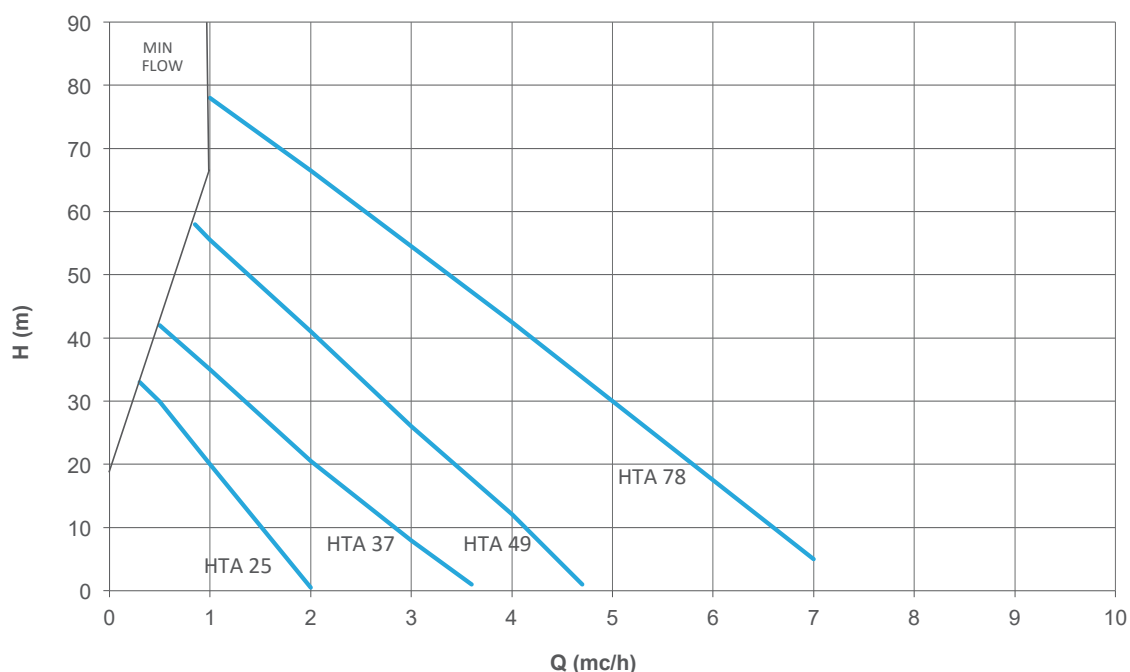

### HTA TECHNICAL DATA

PUMP SIZE	MATERIAL	Q MAX		H MAX		SUCTION CONNECTION	DISCHARGE CONNECTION	PUMP WEIGHT (KG)	SUITABLE MOTOR POWER (Kw) - 2900 rpm	MOTOR FLANGE AND FRAME
		50HZ (M3/H)	60HZ (USGPM)	50HZ (MLC)	60HZ (FT)					
HTA 25	AISI316	2	10	32	140	3/4" FEMALE	3/4" FEMALE	10.3	1.1	80 - B3/B5
HTM 37	AISI316	3.5	19	43	180	3/4" FEMALE	3/4" FEMALE	10.3	1.1	80 - B3/B5
									2.2	90 - B3/B5
HTA 49	AISI316	4.7	25	58	235	1" FEMALE	1" FEMALE	18.7	2.2	90 - B5
									3	100 - B5
HTA 78	AISI316	7	36	76	320	1" FEMALE	1" FEMALE	19	3	100 - B5
									4	112 - B5

### HTA 25-37 SS / EM-T 25-37 SS (ATEX VERSION) DIMENSIONS

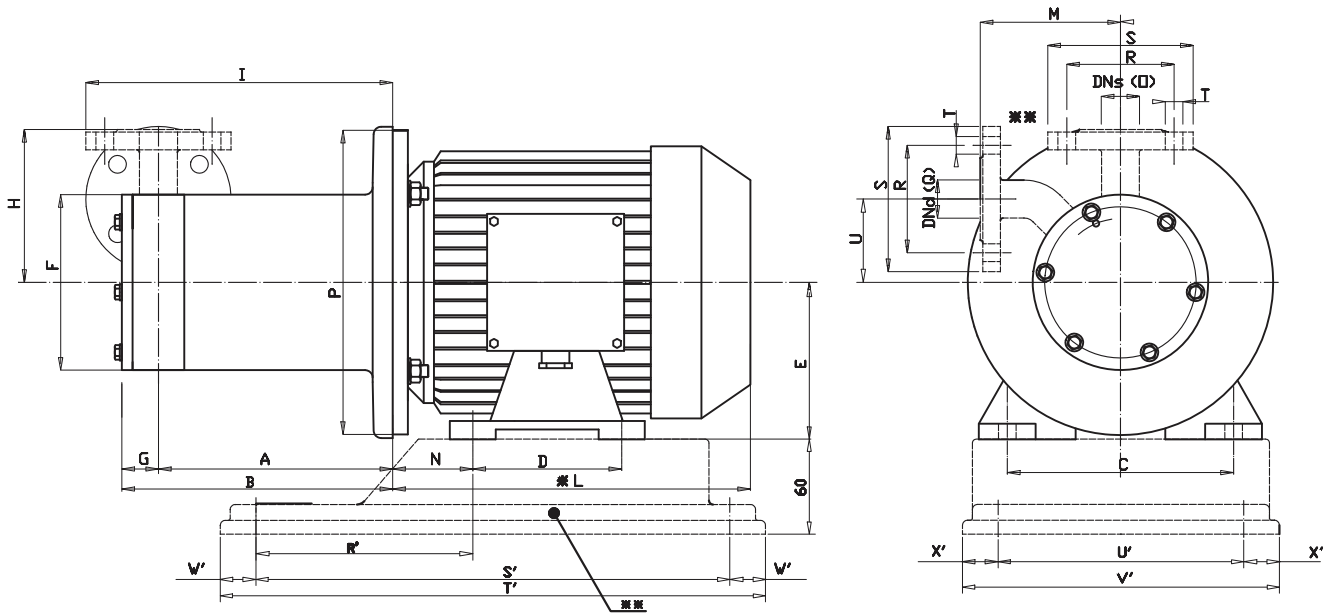

PUMP TYPE	FLANGES DIMENSIONS - mm -					
	R	S	T	DNs	DNd	
HTA 25-37	75	105	14	20	20	DN20 PN40

PUMP TYPE	MOTOR B3 - B5		DIMENSIONS - mm -														BASEPLATE DIMENSIONS - mm -								
	SIZE	KW	A	B	C	D	E	F	G	H	I	*L	M	N	O	P	Q	U	R'	S'	T'	U'	V'	W'	X'
HTA 25	80	1.1	167	192	125	100	80	123	25	100	218	232	98	50	3/4" G. FEMALE	200	3/4" G. FEMALE	61	120	302	350	157	205	24	24
HTA 37	80	1.1	167	192	125	100	80	123	25	100	220	232	98	50	3/4" G. FEMALE	200	3/4" G. FEMALE	61	120	302	350	157	205	24	24
	90	2.2	177	202	140	125	90				230	280		56					132						

\* Different according to the motor supplier. \*\* OPTIONAL UPON REQUEST: Baseplate - Flanges.  
NOTE: DIRECTION OF ROTATION IS COUNTER CLOCKWISE AS SEEN WHEN FACING THE MOTOR.  
PUMPS AVAILABLE THREADED OR FLANGED.

## HTA 49-78 SS / EM-T 49-78 SS (ATEX VERSION) DIMENSIONS

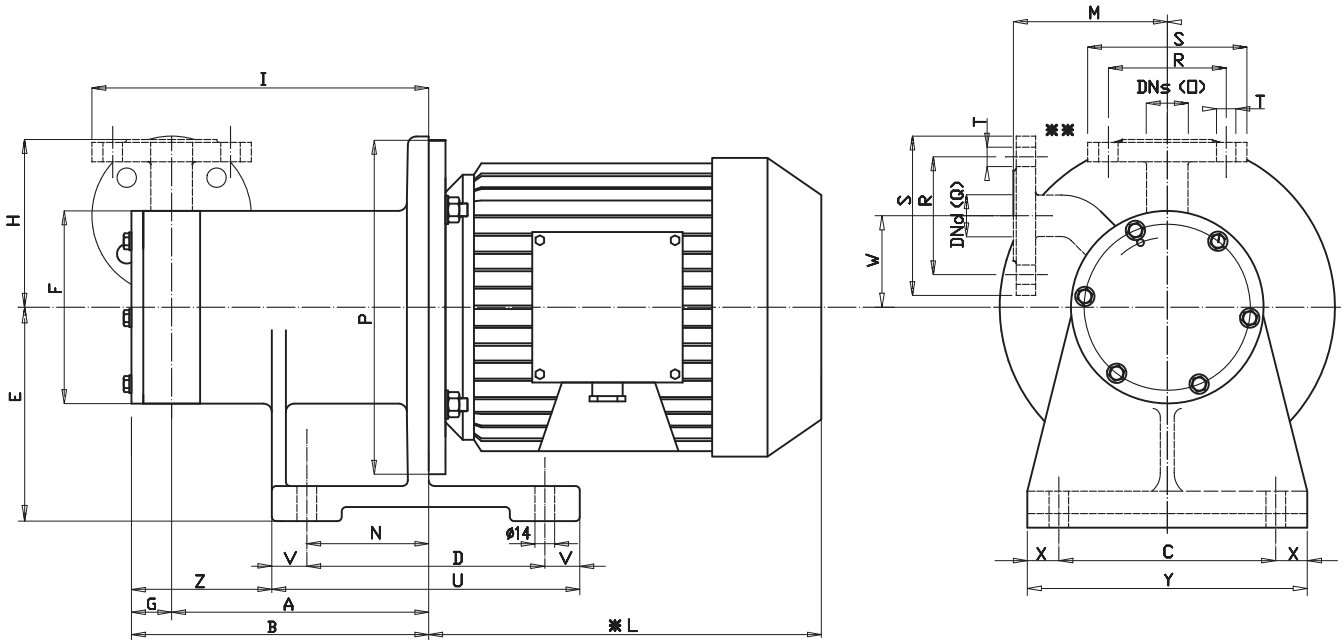

32

PUMP TYPE	FLANGES DIMENSIONS - mm -					
	R	S	T	DNs	DNd	
HTA 49-78	85	115	14	25	25	DN25 PN40

PUMP TYPE	MOTOR B5		DIMENSIONS - mm -																				
	SIZE	KW	A	B	C	D	E	F	G	H	I	*L	M	N	O	P	O	U	V	W	X	Y	Z
HTA 49	90	2.2	185	215	155	170	150	139	30	121	253	280	111	109	1" G. FEMALE	200	1" G. FEMALE	220	25	62.5	22.5	200	91
	100	3	205	235							263	316		119		250							
HTA 78	100	3	205	235	155	170	150	158	30	133	316	316	133	119	1" G. FEMALE	250	1" G. FEMALE	220	25	85.5	22.5	200	91
	112	4									324												

\* Different according to the motor supplier. \*\* OPTIONAL UPON REQUEST: Flanges.  
NOTE: DIRECTION OF ROTATION IS COUNTER CLOCKWISE AS SEEN WHEN FACING THE MOTOR.  
PUMPS AVAILABLE THREADED OR FLANGED.



# MAG-DRIVE ROTARY VANE PUMPS

## SEAL-LESS MAG DRIVE VANE PUMPS

In seal-less magnetic drive vane pumps, the external magnet is directly connected to the motor shaft and it transmits the torque to the internal magnet. The magnetic field created produces a rotation without physical contact between the parts and the rotor spins. The vanes inside the rotor slide in and out of their seat and they move the fluid. The rear casing is placed between the two magnet joints and it hermetically closes the hydraulic part from the motor.

GemmeCotti can supply two different models of volumetric pumps:

### HPP/HPF

- Thermoplastic pumps made in PP or PVDF.
- Capacity up to 1000 l/h.
- Pressure up to 5 bar.

### HTP

- Metallic pumps made in stainless steel AISI316.
- Capacity up to 2100 l/h.
- Pressure up to: 13 bar.
- Dry self-priming.

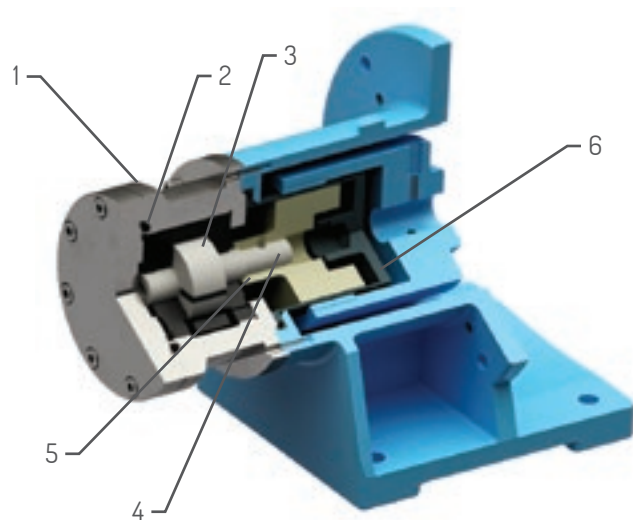

## MATERIALS IN CONTACT WITH THE LIQUID

PART NUMBER - DESCRIPTION	VANE PUMPS	
	HPP/HPF	HTP
1 - PUMP BODY+ COVER	PP OR PVDF	AISI 316
2- O-RING	EPDM OR VITON	EPDM OR VITON
3- FLANGES STATOR VANES + PINS	PVDF + GRAPHITE	GRAPHITE
4- ROTOR SHAFT	PVDF	AISI 316
5- INTERNAL MAGNET	PP OR PVDF + NdFeB	AISI 316 + SmCo
6- REAR CASING	PP OR PVDF	AISI 316

## THERMOPLASTIC MAG-DRIVE ROTARY VANE PUMPS



### SYSTEM PRESSURE

8 bar.

### STANDARD

- High torque magnetic coupling.
- Direct starting motor.

### OPTIONAL

- Flanges available.
- Dry-running protection.
- Baseplate.

### MAIN FEATURES

Mag drive rotary vane pumps series HPP-HPF are made of thermoplastic materials (PP/PVDF) and are suitable for corrosive liquids, alkalis, toxic, noxious and carcinogenic fluids.

Thanks to the innovative mag drive system, pumps model HPP-HPF reduce the risks of leakage and the maintenance costs. HPP-HPF pumps are useful for low flow and high head applications such as Pilot Plants and Sampling.

### MATERIALS AVAILABLE

- PP, PVDF.
- Materials in contact with the liquid: casing, end cover, internal magnet and rear casing: PP/PVDF; o-ring: EPDM (standard for PP pumps); VITON (standard for PVDF pumps).
- Graphite Stator.
- Rotor shaft: PVDF.

### PERFORMANCES

Max flow 1000 l/h. Max pressure 5 bar.

### TEMPERATURE

PP: max 70°C - PVDF: max 90°C.

## PERFORMANCE CURVES 50HZ - 1450 RPM

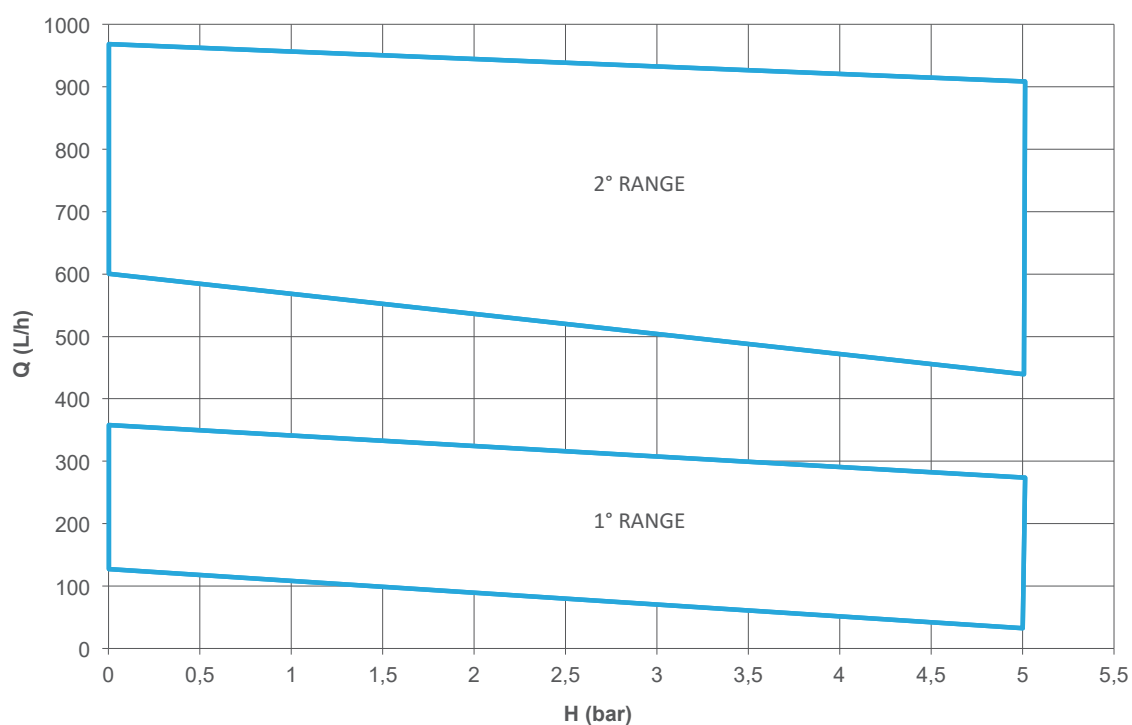

### HPP/HPF TECHNICAL DATA

PUMP SIZE	MATERIAL	Q MAX		H MAX		SUCTION CONNECTION	DISCHARGE CONNECTION	PUMP WEIGHT (KG)		SUITABLE MOTOR POWER (KW) - 1450 rpm	MOTOR FLANGE AND FRAME
		50HZ (l/h)	60HZ (usgpm)	50HZ (bar)	60HZ (PSI)			PP	PVDF		
HPP/HPF 100 1R	PP- PVDF	120	0.66	5	72	3/8" FEMALE	3/8" FEMALE	2.9	3.2	0,37	71 - B3/B5
HPP/HPF 200 1R	PP- PVDF	200	1.1	5	72	3/8" FEMALE	3/8" FEMALE	2.9	3.2	0,37	71 - B3/B5
HPP/HPF 300 1R	PP- PVDF	290	1.5	5	72	3/8" FEMALE	3/8" FEMALE	2.9	3.2	0,37	71 - B3/B5
HPP/HPF 400 1R	PP- PVDF	360	1.85	5	72	3/8" FEMALE	3/8" FEMALE	2.9	3.2	0,37	71 - B3/B5
HPP/HPF 600 2R	PP- PVDF	600	2.5	5	72	1/2" FEMALE	1/2" FEMALE	7	7.5	1,5	90 - B3/B5
HPP/HPF 800 2R	PP- PVDF	800	3	5	72	1/2" FEMALE	1/2" FEMALE	7	7.5	1,5	90 - B3/B5
HPP/HPF 1000 2R	PP- PVDF	990	3.5	5	72	1/2" FEMALE	1/2" FEMALE	7	7.5	1,5	90 - B3/B5

### HPP-HPF 1° RANGE DIMENSIONS

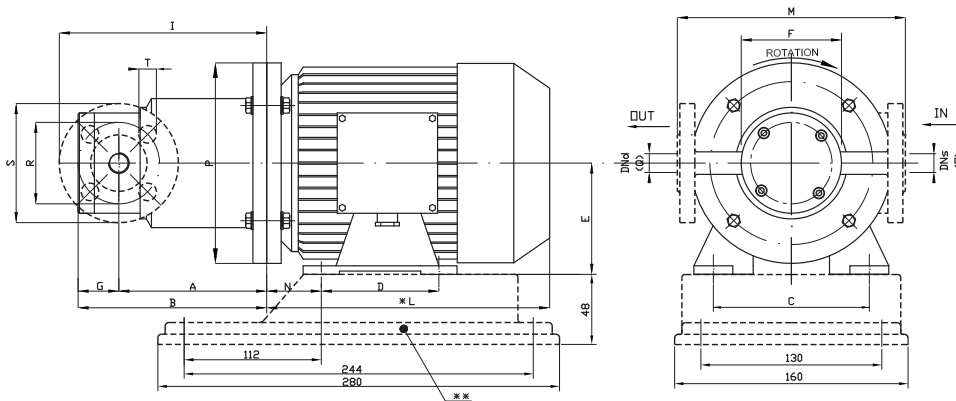

### HPP-HPF 2° RANGE DIMENSIONS

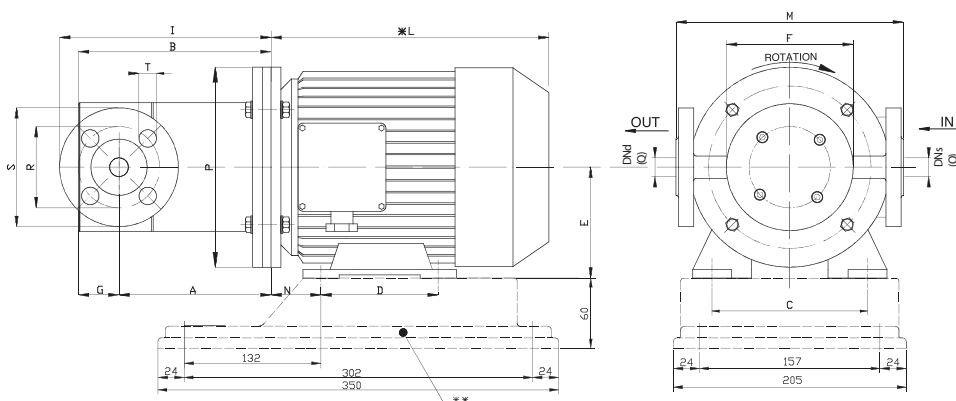

PUMP TYPE	FLANGES DIMENSIONS - mm - DN 15 PN 16				
	R	S	T	DNs	DNd
HPP-HPF 1° RANGE	65	95	14	15	15

PUMP TYPE	FLANGES DIMENSIONS - mm - DN 20 PN 16				
	R	S	T	DNs	DNd
HPP-HPF 2° RANGE	75	105	14	20	20

PUMP TYPE	MOTOR FLANGE B3 - B5	KW	DIMENSIONS - mm -													
			A	B	C	D	E	F	G	I	*L	M	N	O	P	Q
HPP-HPF 1° RANGE	71-4B	0,37	128	164	112	90	71	90	36	175	215	182	45	3/8"G.	160	3/8"G.
HPP-HPF 2° RANGE	90-52	1,5	169	213	140	100	90	127	44	222	255	218	56	1/2"G.	200	1/2"G.

\* Different according to the manufacturer.

\*\* OPTIONAL UPON REQUEST: Baseplate - Flanges.

## METALLIC ROTARY VANE MAG-DRIVE PUMPS DRY SELF-PRIMING



### STANDARD

- High torque magnetic coupling.
- Direct starting motor.

### OPTIONAL

- Flanges available.
- Dry-running protection.
- Baseplate.
- ATEX version (pump mod. EM-P).
- Explosion proof motor.

### MAIN FEATURES

Rotary vane mag drive pumps series HTP are made of AISI 316 or, if requested, of other metallic materials (Titanium and Hastelloy) and are suitable for hydrocarbons, solvents, heat transfer oils, refrigerants, cryogenics and radioactive liquids. Thanks to the innovative mag drive system, pumps model HTP reduce the risks of leakage and emissions and the maintenance costs. HTP pumps are useful for low flow and high head applications such as Pilot Plants, Sampling and Flushing of mechanical seals. Especially designed for thin non-lubricating liquids and/or high differential pressure.

Pumps series HTP are also available in ATEX version for zone 1 and 2 (pump model EM-P).

- Materials available: AISI 316.
- Materials in contact with the liquid:  
pump body, end cover and rotor: AISI 316;  
o-ring: EPDM/VITON; carbon graphite stator.
- Max flow: 2100 l/h. Max pressure 13 bar.
- Temperature range: from - 70°C to + 200°C.
- Max viscosity: 2000 cPs.
- System Pressure 25 bar.

## PERFORMANCE CURVES 50HZ - 1450 RPM

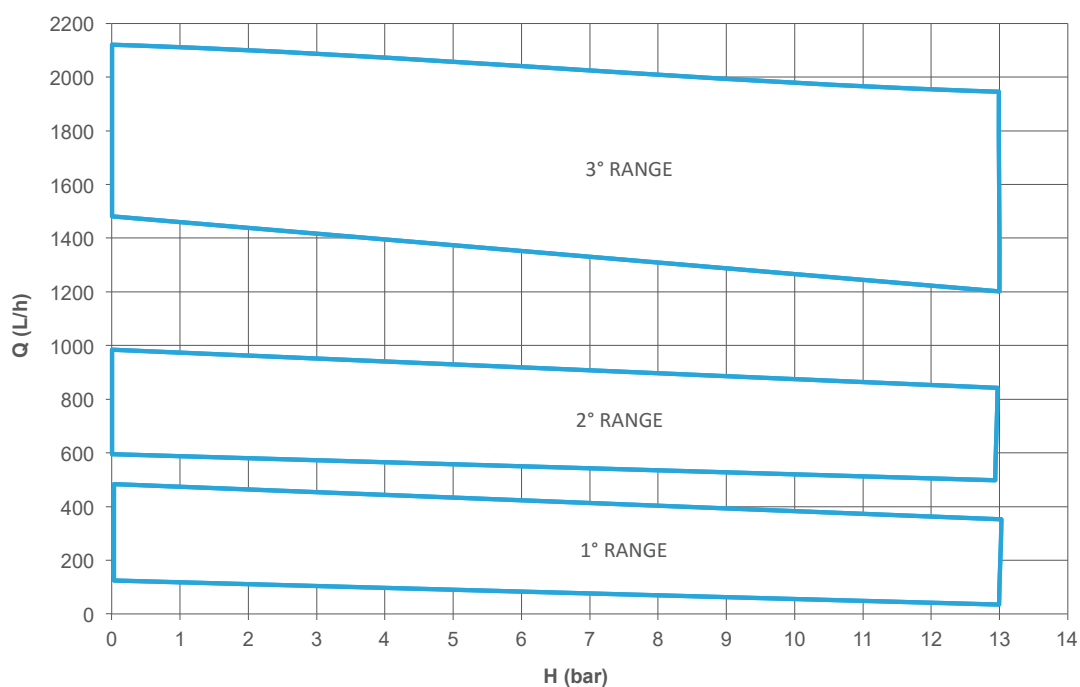

### HTP TECHNICAL DATA

PUMP SIZE	MATERIAL	Q MAX		H MAX		SUCTION CONNECTION	DISCHARGE CONNECTION	PUMP WEIGHT (KG)	SUITABLE MOTOR POWER (Kw) - 1450 rpm	MOTOR FLANGE AND FRAME
		50HZ (l/h)	60HZ (usgpm)	50HZ (bar)	60HZ (PSI)					
HTP 100 1R	AISI316	120	0.66	13	188	3/8" FEMALE	3/8" FEMALE	5	0,37	71 - B3/B5
HTP 200 1R	AISI316	250	1.4	13	188	3/8" FEMALE	3/8" FEMALE	5	0,37	71 - B3/B5
HTP 300 1R	AISI316	350	1.9	13	188	3/8" FEMALE	3/8" FEMALE	5	0,37	71 - B3/B5
HTP 400 1R	AISI316	450	2.3	13	188	3/8" FEMALE	3/8" FEMALE	5	0,37	71 - B3/B5
HTP 600 2R	AISI316	600	3.3	13	188	1/2" FEMALE	1/2" FEMALE	8.3	0,75	80 - B3/B5
HTP 800 2R	AISI316	800	4.3	13	188	1/2" FEMALE	1/2" FEMALE	8.3	0,75	80 - B3/B5
HTP 1000 2R	AISI316	980	5	13	188	1/2" FEMALE	1/2" FEMALE	8.3	1,5	90 - B3/B5
HTP 1500 3R	AISI316	1500	8	13	188	3/4" FEMALE	3/4" FEMALE	19.5	1,5	90 - B5
HTP 2000 3R	AISI316	2100	11.1	13	188	3/4" FEMALE	3/4" FEMALE	19.5	2,2	100 - B5
									3	100 - B5
									4	112 - B5

### HTP 1°-2° RANGE / EM-P 1°- 2° RANGE (ATEX VERSION) DIMENSIONS

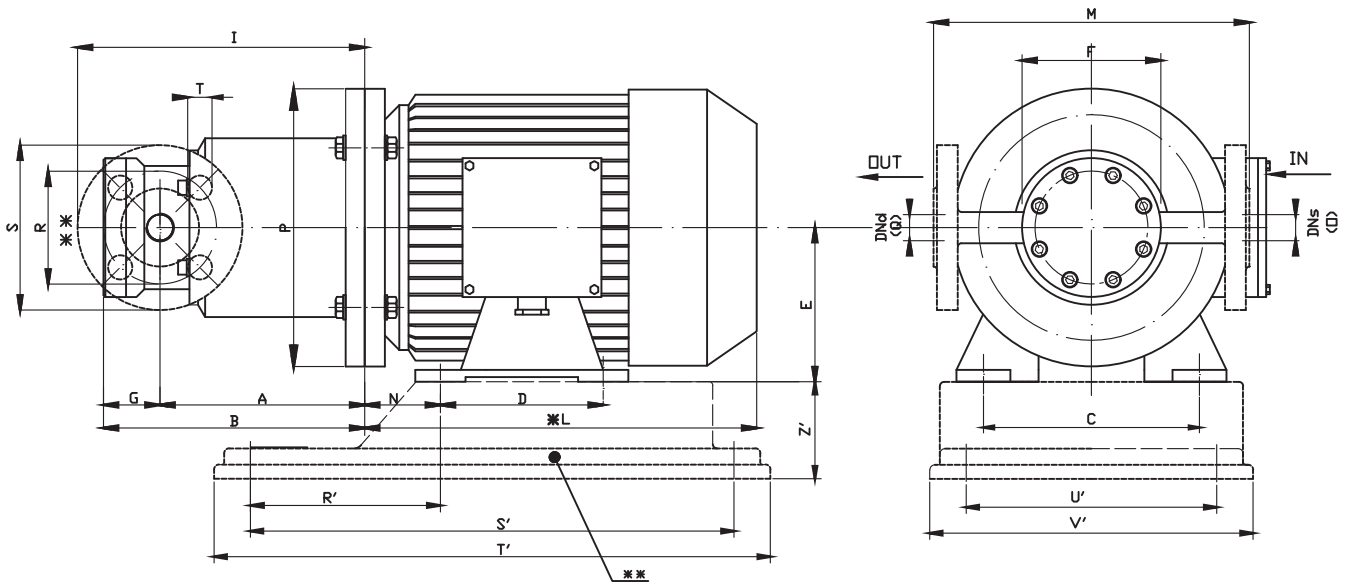

PUMP TYPE	FLANGES DIMENSIONS - mm -					
	R	S	T	DN <sub>s</sub>	DN <sub>d</sub>	
HTP 1° RANGE	65	95	14	15	15	DN15 PN40
HTP 2° RANGE	75	105	14	20	20	DN20 PN40

PUMP TYPE	MOTOR FLANGE B3 - B5	Kw	DIMENSIONS - mm -													BASEPLATE DIMENSIONS - mm -						
			A	B	C	D	E	F	G	I	*L	M	N	O	P	Q	R'	S'	T'	U'	V'	Z'
HTP 1° RANGE	71	0,37	127	160	112	90	71	80	33	175	215	182	45	3/8"G.	160	3/8"G.	112	244	280	130	160	48
HTP 2° RANGE	80	0,75	166	204	125	100	80				232						120					
	90 S	1,5	176	214	140	125	90	123	38	218	280	194	56	1/2"G.	200	1/2"G.	132	302	350	157	205	60

\* Different according to the motor supplier. \*\* OPTIONAL UPON REQUEST: Baseplate - Flanges.  
NOTE: DIRECTION OF ROTATION IS COUNTER CLOCKWISE AS SEEN WHEN FACING THE MOTOR.  
PUMPS AVAILABLE THREADED OR FLANGED.

## HTP 3° RANGE / EM-P 3° RANGE (ATEX VERSION) DIMENSIONS

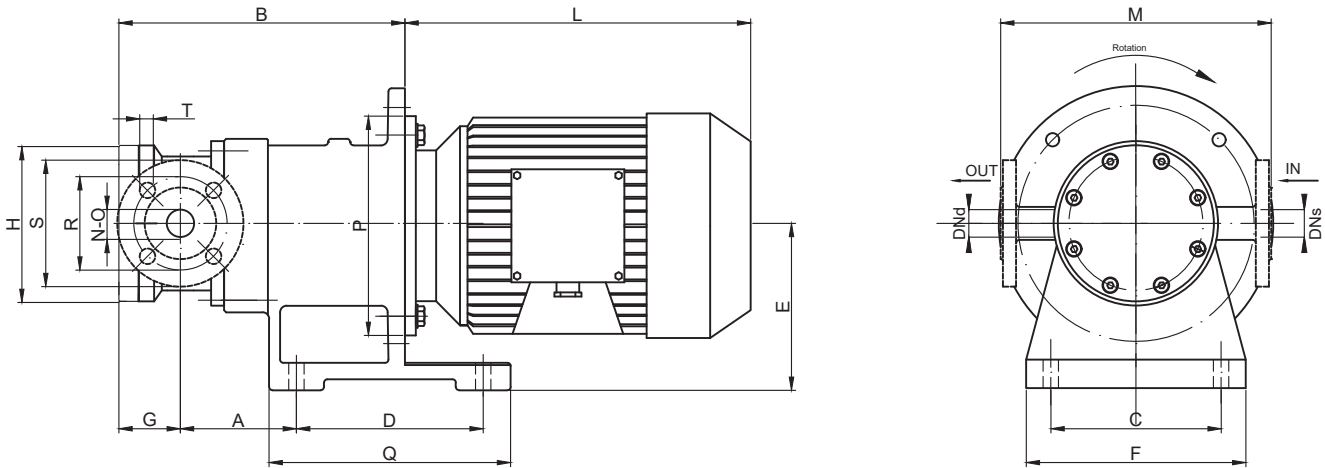

PUMP TYPE	FLANGES DIMENSIONS - mm -					
	R	S	T	DNs	DNd	
HTP 3° RANGE	85	115	14	25	25	DN25 PN40

PUMP TYPE	MOTOR B5 4P		DIMENSIONS - mm -													
	SIZE	KW	A	B	C	D	E	F	G	H	*L	M	N	O	P	Q
HTP 3° RANGE	90L	1.5	106	260	155	170	150	200	56	142	280	246	3/4" G.	3/4" G.	200	220
	100L	2.2 / 3	106	280	155	170	150	200	56	142	316	246	3/4" G.	3/4" G.	250	220
	112M	4	106	280	155	170	150	200	56	142	334	246	3/4" G.	3/4" G.	250	220

\* Different according to the motor supplier. \*\* OPTIONAL UPON REQUEST: Flanges.  
NOTE: DIRECTION OF ROTATION IS COUNTER CLOCKWISE AS SEEN WHEN FACING THE MOTOR.  
PUMPS AVAILABLE THREADED OR FLANGED.

# MECHANICAL SEAL CENTRIFUGAL PUMPS

## MECHANICAL SEAL CENTRIFUGAL PUMPS

Mechanical seal centrifugal pumps are the right solution for applications involving solids in the liquid because their design with open impeller allows to pump dirty liquids and fluids with high viscosity. The seal in mechanical seal pumps is composed by a static ring and a rotating ring placed on the pump shaft which is directly coupled to the motor shaft. The two surfaces sliding together need to be lubricated and the seal lubricant is the liquid itself that is being pumped.

GemmeCotti can supply the following model of mechanical seal pump:

### HCO

- Thermoplastic pumps made in PP or PVDF.
- Capacity up to 58 m<sup>3</sup>/h.
- Head up to 38 m.c.
- Two different kind of mechanical seal available:  
lip seal for model HCO 95-10, internal PTFE bellow mechanical seal for all the other pump sizes.

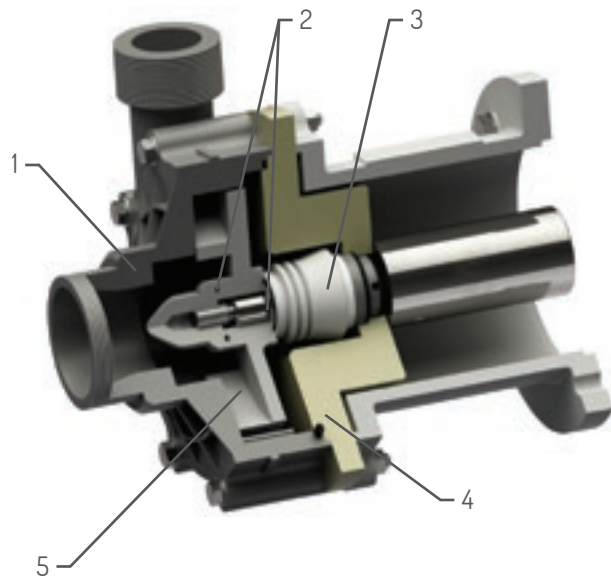

MATERIALS IN CONTACT WITH THE LIQUID	
PART NUMBER - DESCRIPTION	MECHANICAL SEAL PUMPS
	HCO
1 - PUMP HEAD	PP OR PVDF
2 - O-RING	EPDM - VITON
3- MECHANICAL SEAL	PTFE + Al <sub>2</sub> O <sub>3</sub>
4- COVER	PP OR PVDF
5- IMPELLER + IMPELLER NUT	PP OR PVDF

## MECHANICAL SEAL CENTRIFUGAL PUMPS



### STANDARD

- Gas threaded in and out connections.
- Direct starting motor.

### OPTIONAL

- Flanges available.
- Dry-running protection.
- Baseplate.

### MAIN FEATURES

Centrifugal pumps series HCO with mechanical seal are made of thermoplastic materials (Polypropylene and PVDF) and are suitable for high corrosive liquids containing solids in suspension. The seal of pumps HCO size 95-10 is guaranteed by a special elastomeric lip seal, while all the other pump sizes (from size 110 to 170) are equipped with an internal PTFE bellows mechanical seal (sic/ceramic), which is manufactured by GemmeCotti.

- Materials available: PP / PVDF.
- Flow up to 60 m<sup>3</sup>/h; Head up to 38 m.
- Temperature: PP: max 70° C - PVDF: max 90° C.
- Max viscosity: 200 cSt.
- Pressure rating: NP 6 at 20° C.
- Lip seal for pumps size 95-10; internal PTFE bellows mechanical seal for all the other sizes.
- Suitable for high corrosive liquids containing solids in suspension.

## PERFORMANCE CURVES 50HZ - 2900 RPM

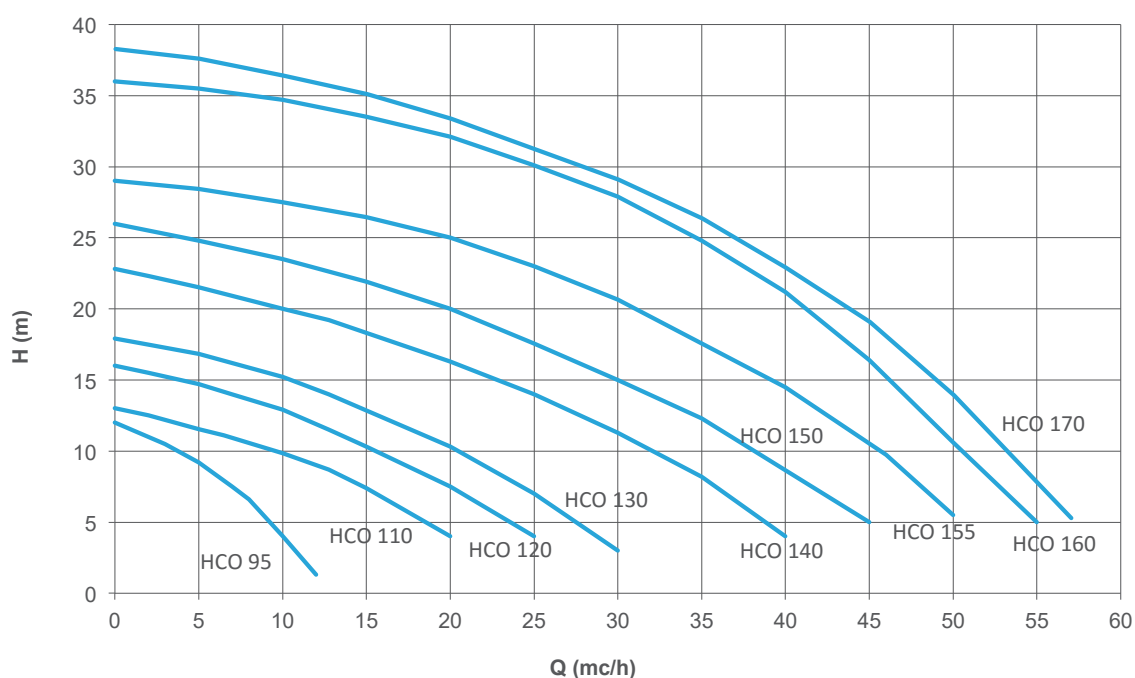



### HCO TECHNICAL DATA

PUMP SIZE	MATERIAL	Q MAX		H MAX		SUCTION CONNECTION	DISCHARGE CONNECTION	PUMP WEIGHT (KG)		SUITABLE MOTOR POWER (KW) - 2900 rpm	MOTOR FLANGE AND FRAME
		50HZ (m3/h)	60HZ (usgpm)	50HZ (mle)	60HZ (FT)			PP	PVDF		
HCO 95-10	PP- PVDF	12	52	12	47	1 1/2" FEMALE	1" MALE	10	12	0,55	71 - B3/B5
HCO 110	PP- PVDF	20	88	13	59	2 1/2" MALE	2" MALE	10	12	1,1	80 B - B3/B5
HCO 120	PP- PVDF	25	100	16	75	2 1/2" MALE	2" MALE	10	12	1,5	90 S - B3/B5
HCO 130	PP- PVDF	30	158	18	90	2 1/2" MALE	2" MALE	10	12	2,2	90 L - B3/B5
HCO 140	PP- PVDF	40	212	22	104	2 1/2" MALE	2" MALE	11	13	3	100 L - B3/B5
HCO 150	PP- PVDF	45	242	26	124	3" MALE	2 1/2" MALE	11	13	5,5	132 S - B3/B5
HCO 155	PP- PVDF	50	265	29	140	3" MALE	2 1/2" MALE	11	13	5,5	132 S - B3/B5
HCO 160	PP- PVDF	55	290	36	170	3" MALE	2 1/2" MALE	11	13	7,5	132 M - B3/B5
HCO 170	PP- PVDF	58	300	38	175	3" MALE	2 1/2" MALE	11	13	7,5	132 M - B3/B5

### HCO 95/10 - 110 - 120 - 130 - 140 - 150 - 155 - 160 - 170 PP/PVDF DIMENSIONS

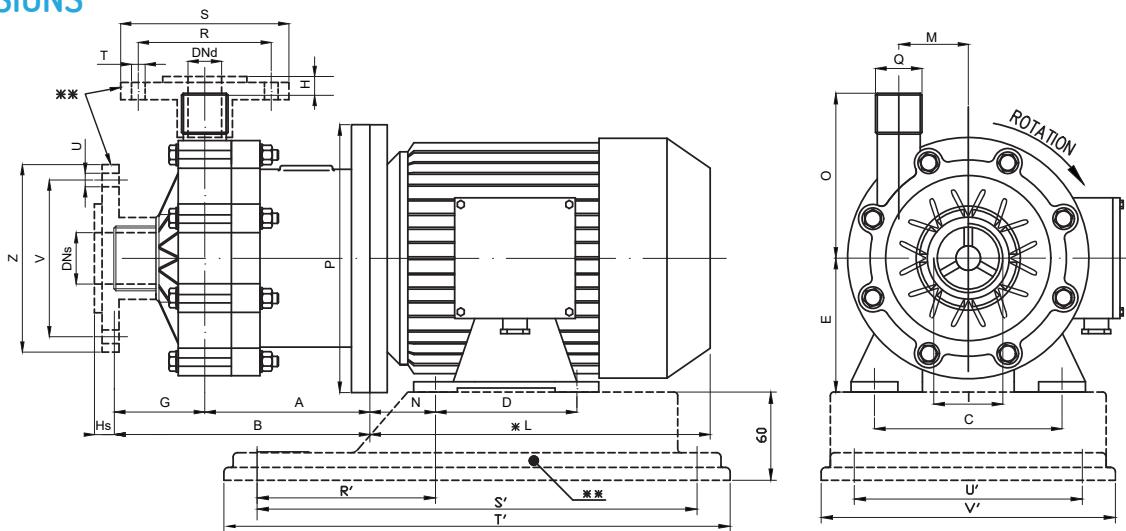

PUMP TYPE	FLANGES DIMENSIONS - mm -							
	R	S	T	U	V	Z	DNs	DNd
HCO 95-10	85	115	14	18	110	150	40	25
HCO 110 - 120 - 130 - 140	125	168	18	18	145	188	65	50
HCO 150 - 155 - 160 - 170	145	188	18	18	160	203	80	65

PUMP TYPE	BASEPLATE DIMENSIONS - mm -				
	R'	S'	T'	U'	V'
HCO 95-10	112	244	280	130	160
HCO 110 - 120 - 130	120	302	350	157	205
HCO 140	140	352	400	202	250

PUMP TYPE	MOTOR FLANGE B3 - B5	Kw	DIMENSIONS - mm -														
			A	B	C	D	E	G	Hs	H	I	- L	M	N	O	P	Q
HCO 95-10	71 B	0,55	110	180	112	90	71	70	20	9	1 1/2 FEMALE	215	45	45	100	160	1" MALE
HCO 110	80 B	1,1	209	290	125	100	80	91	10	13	2 1/2 MALE	232	66	50	140	200	2" MALE
HCO 120	90 S	1,5	209	290	140	100	90	91	10	13	2 1/2 MALE	255	66	56	140	200	2" MALE
HCO 130	90 L	2,2	209	290	140	125	90	91	10	13	2 1/2 MALE	280	66	56	140	200	2" MALE
HCO 140	100	3	219	310	160	140	100	91	10	13	2 1/2 MALE	315	66	63	140	250	2" MALE
HCO 150 - HCO 155	132 S	5,5	184	275	216	140	132	91	10	10	3" MALE	380	82,5	89	170	300	2 1/2 MALE
HCO 160 - HCO 170	132 M	7,5	184	275	216	178	132	91	10	10	3" MALE	420	82,5	89	170	300	2 1/2 MALE

OPTIONAL UPON REQUEST: Baseplate (except pumps model from HCO 150 -155- 160- 170) - Flanges.  
 NOTE: DIRECTION OF ROTATION IS COUNTER CLOCKWISE AS SEEN WHEN FACING THE MOTOR.  
 PUMPS AVAILABLE THREADED OR FLANGED.

# LIQUID RING VACUUM PUMPS

## LIQUID RING VACUUM PUMPS SUITABLE FOR TOXIC, OBNOXIOUS AND DANGEROUS GASES & VAPOURS.

- TYPE: VPM (magnetic drive design).
- TYPE: VPS (close coupled with mechanical seal).
- TYPE: VPL (long coupled with mechanical seal).

GEMMECOTTI liquid ring vacuum pumps types VPM, VPS, and VPL, are constructed in a conventional overhung impeller design. They are suitable for operating with both toxic and dangerous gases. GEMMECOTTI liquid ring vacuum pumps attain high levels of vacuum by means of isothermal compression. They can evacuate most gases and vapors and are especially suitable for the evacuation of gases containing both condensate and liquid compositions for arduous applications. GEMMECOTTI liquid ring vacuum pumps generally operate without contact between internal rotating parts, with the exception of the mechanical seal rings for pumps VPS and VPL and the rotating bushes for pump VPM (magnetic drive). Due to their inherent design, contact is required, however, the service liquid ensures that both the mechanical seal and bushes are lubricated sufficiently in these designs. VPM, VPS, and VPL models are also capable of operating without the need for an external lubrication source, as the standard design uses sealed for life bearings. Vibration and noise levels are minimized and fall well below industry requirements on all models within the range. VPM, VPS and VPL have the capability to incorporate automatic drain and anti-cavitation valves.

### DESIGN

**VPM** range: Sealless pump, magnetic drive. Support is guaranteed by standard design of silicon carbide

slide bearing.

**VPS** range: available in close coupled design and fitted with single mechanical seal. Supported by means of standard bearings fitted to the electric motor.

**VPL** range: Standard execution with single mechanical seal. For more arduous duties it is also possible to install a double mechanical seal with an external flushing system. Support by a robust bearing bracket complete with sealed for life ball bearings. GemmeCotti can also install an oil lubricated ball bearing design for this construction if requested.

### OPERATIONS

In order to operate successfully all vacuum pumps have to be filled in with a suitable service liquid (usually water or a compatible liquid suitable for the gas to be evacuated). This allows a constant gas compression for the application and also removes the heat generated during operation of the cycle. Continuous service liquid has to be fed to the pump for the vacuum level to be maintained and for the pump to operate efficiently. There are three standard designs of service liquid feed that can be used with any vacuum pump:

- Open Circuit (often referred to as total loss or oncthrough).
- Closed Circuit (often referred to as total recirculation).
- Semi-Open Circuit (often referred to as partial recirculation).

## LIQUID RING VACUUM PUMPS



### FEATURES

- Cast casing and impeller in Stainless Steel AISI 316, Titanium, Hastelloy C.
- Cast Iron/Carbon Steel bracket (VPL & VPM only).
- No contact between internal rotating parts, except for mechanical seal rings (pumps VPS and VPL) and rotating bushes (pump VPM magnetic drive).
- No need for external lubrication source to operate.
- Easy maintenance.
- High efficiency with reduced dimensions.
- Minimum vibration values/low noise
- Versatile for different applications.
- Design temperature: 100°C.
- Pressure rating: NP 10.

### STANDARD

- Overhung impeller design.
- Isothermal Compression.

### OPTIONAL

- Automatic drain and anti-cavitation valves.
- Graphite/Ceramic mechanical seal.
- Oil lubricated ball bearing (only VPL).
- ATEX Certification.

## PERFORMANCE CURVES 50HZ - 1450 RPM

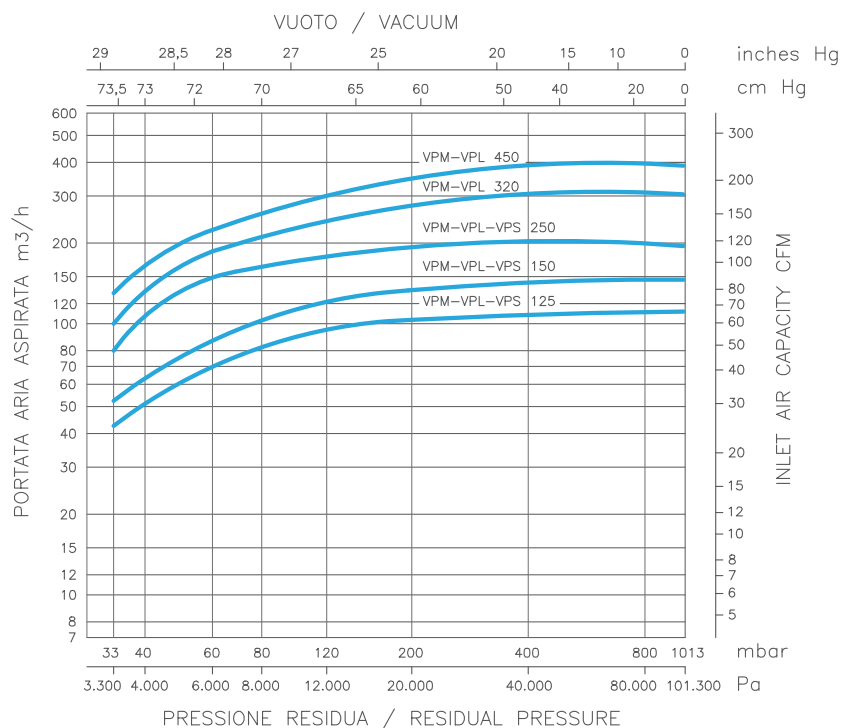

VPM / VPS /VPL TECHNICAL DATA

PUMP SIZE	MATERIAL	Q MAX (M3/H)		SUCTION CONNECTION (DN)	DISCHARGE CONNECTION (DN)	SUITABLE MOTOR POWER (KW) - 1450 rpm
		50HZ (m3/h)	60HZ (m3/h)			
VPM/VPL 125	AISI316	120	140	40	40	3
VPM/VPL 150	AISI316	150	200	40	40	4
VPM/VPL 250	AISI316	200	250	80	80	5,5
VPM/VPL 320	AISI316	300	400	80	80	7,5
VPM/VPL 450	AISI316	400	510	80	80	11
VPS 125	AISI316	120	140	40	40	3
VPS 150	AISI316	150	200	40	40	4
VPS 250	AISI316	200	250	80	80	5,5

VPM 125, 150, 250, 320, 450 DIMENSIONS

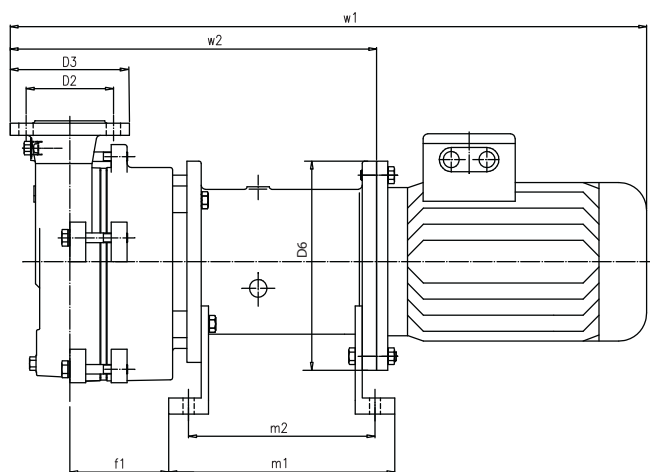

MOTOR: MOUNTING B5, 4 POLES, 50/60 CYCLES

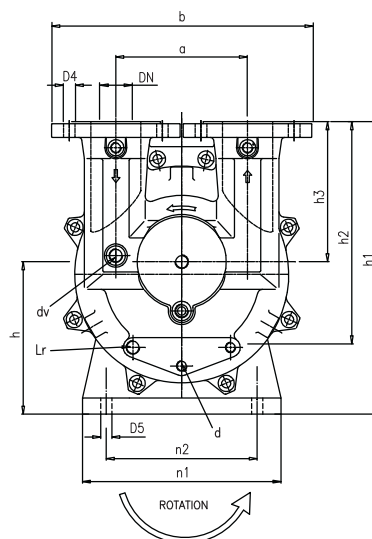

DIMENSIONS - mm -																			Weight Kg *	Service Fluid m <sup>3</sup> /h
VPM	IEC	K <sub>w</sub>	Hz	RPM	A	B	D6	F1	H	H1	H2	H3	M1	M2	N1	N2	W1	W2		
125	100	3	50	1450	180	330	250	110	180	355	305	175	240	200	230	190	700	385	115	0,8
	112	4	60	1750													710		120	0,8
150	112	4	50	1450	180	330	250	125	180	355	305	175	240	200	230	190	725	400	130	0,8
	132 S	5,5	60	1750													745		170	0,8
250	132 S	5,5	50	1450	205	405	300	219	230	445	345	215	340	300	300	240	920	535	240	1,2
	132 M	7,5	60	1750													960		250	1,2
320	132 M	7,5	50	1450	205	405	300	275	230	445	345	215	340	300	300	240	998	575	257	1,4
	160 M	11	60	1750													1085		297	1,4
450	160 M	11	50	1450	205	405	350	312	230	445	345	215	340	300	300	240	1120	611	307	1,5
	160 L	15	60	1750													1145		322	1,5

\* Weight refers to AISI 316 pump.

FLANGES DN PN 10/16 (mm)					
VPM	DN	D2	D3	D4	D5
125 - 150	40	110	150	18	18
250 - 320 - 450	80	160	200	19	18

d	DRAIN CONNECTION	3/8" G.
dv	AUTOMATIC DRAIN VALVE CONNECTION	1/2" G.
Lr	LIQUID RING CONNECTION	1/2" G.

## VPM 125, 150, 250, 320, 450 SECTION AND PART LIST

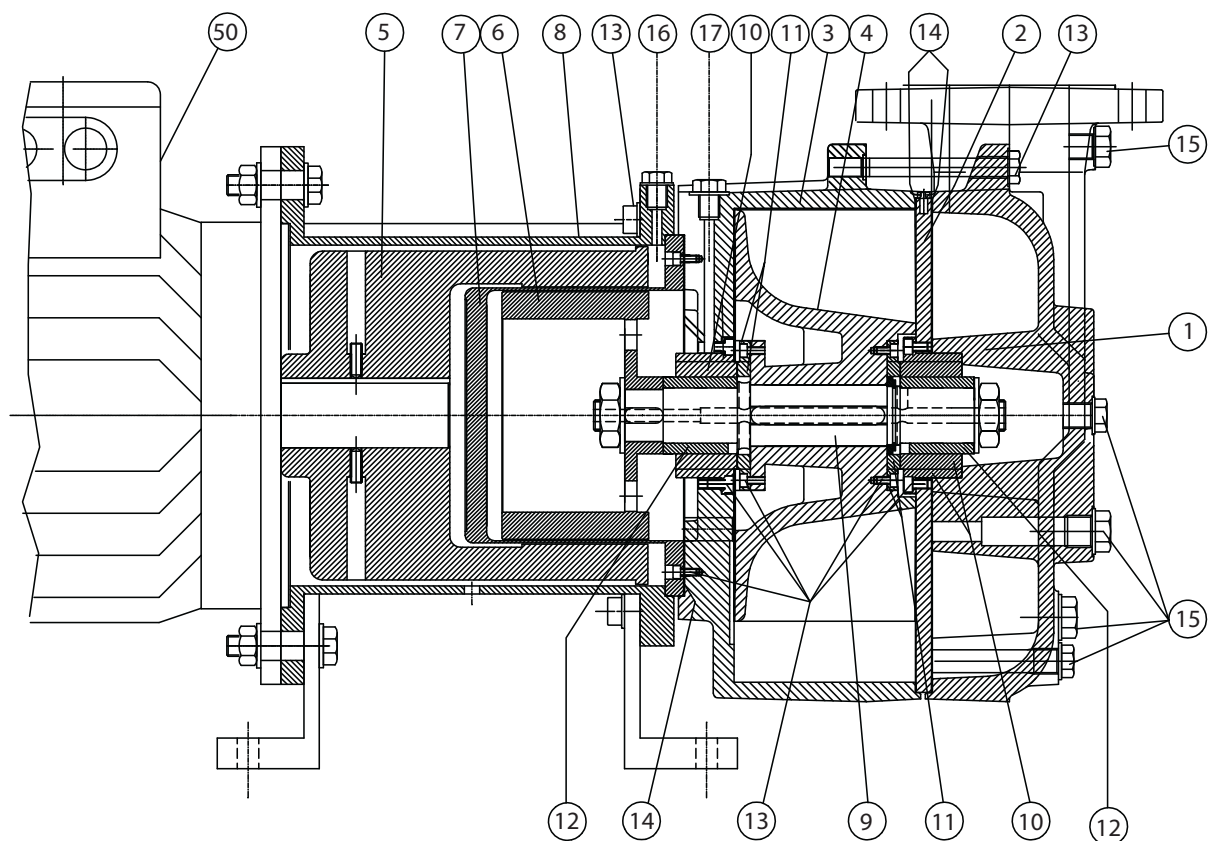

POS.	DESCRIPTION
1	END SHIELD
2	PORT PLATE
3	CASING
4	IMPELLER
5	EXT. MAGNET
6	INT. MAGNET

POS.	DESCRIPTION
7	REAR CASING
8	BRACKET
9	SHAFT
10	SET STATIC BUSHING
11	SET AXIAL THRUST BUSHING
12	SET ROTATING BUSHING

POS.	DESCRIPTION
13	SET SCREW
14	SET CASING GASKET
15	SET CASING GASKET
16	PT 100 REAR CASING
17	PT 100 STATIC BUSHING
50	MOTOR

## LIQUID RING VACUUM PUMPS

### VPS 125, 150, 250 DIMENSIONS

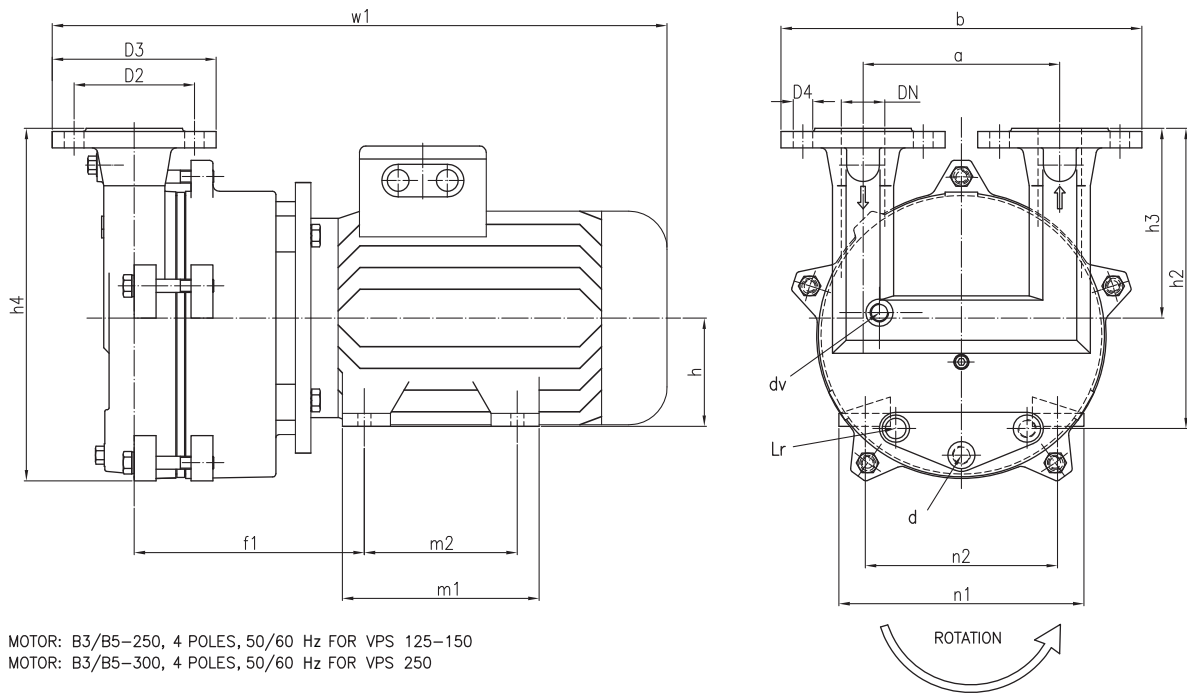

MOTOR: B3/B5-250, 4 POLES, 50/60 Hz FOR VPS 125-150  
MOTOR: B3/B5-300, 4 POLES, 50/60 Hz FOR VPS 250

DIMENSIONS - mm -																	Weight	Service					
VPS	IEC	Kw	Hz	RPM	A	B	F1	H	H2	H3	H4	M1	M2	N1	N2	W1	Kg *	m <sup>3</sup> /h					
125	100	3	50	1450	180	330	211	100	305	175	340	175	140	200	160	523	75	0.8					
	112	4	60	1750			218	112				180		245	190	558	80	0.8					
150	112	4	50	1450			232	132				345		215	420	200	280	216	643	95	0.8		
	132 S	5.5	60	1750			273									200			664	120	1.2		
250	132 S	5.5	50	1450	200	390	266		345	215	420		238			178			280	216	664	120	1.2
	132 M	7.5	60	1750																	238	178	701

\* Weight refers to AISI 316 pump

FLANGES DN PN 10/16 (mm)				
VPS	DN	D2	D3	D4
125 - 150	40	110	150	18
250	80	145	190	18

d	DRAIN CONNECTION	3/8" G.
dv	AUTOMATIC DRAIN VALVE CONNECTION	1/2" G.
Lr	LIQUID RING CONNECTION	1/2" G.

## VPS 125, 150, 250

### SECTION AND PART LIST

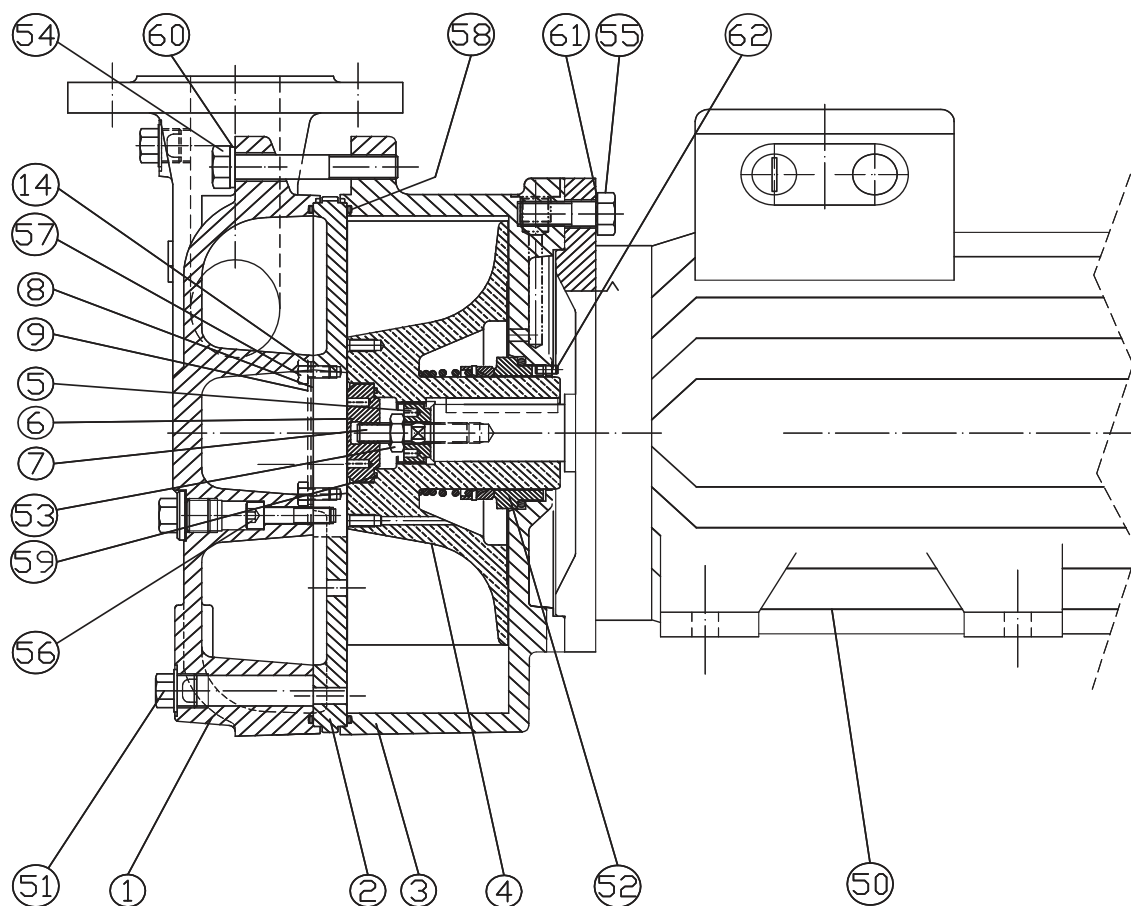

POS.	DESCRIPTION
1	END SHIELD
2	PORT PLATE
3	CASING
4	IMPELLER
5	SET COLLAR
6	COVER PLATE
7	STUD BOLT
8	VALVE

POS.	DESCRIPTION
9	VALVE PLATE
14	WASHER
50	MOTOR
51	LOCKING SCREW
52	MECHANICAL SEAL
53	NUT
54	SCREW
55	SCREW

POS.	DESCRIPTION
56	SCREW
57	SCREW
58	O-RING
59	O-RING
60	WASHER
61	WASHER
62	PIN

## VPL 125, 150, 250, 320, 450 DIMENSIONS

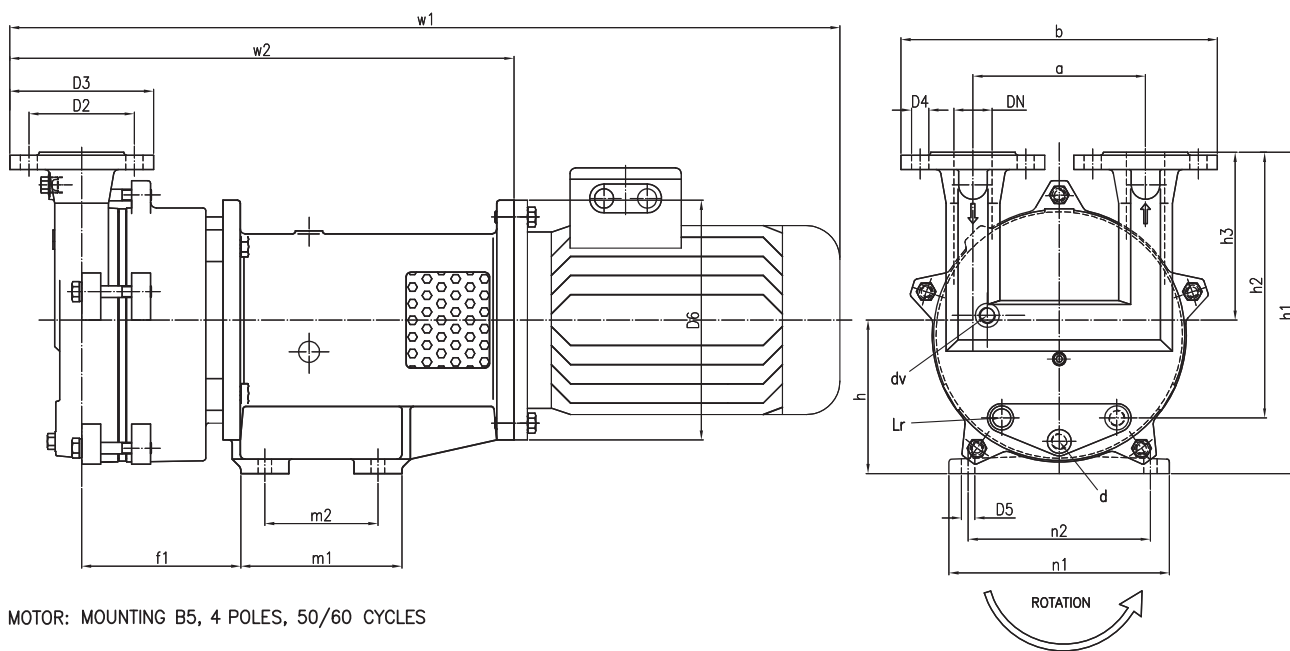

48

MOTOR: MOUNTING B5, 4 POLES, 50/60 CYCLES

DIMENSIONS - mm -																		Weight Kg *	Service Fluid m <sup>3</sup> /h
VPL	IEC	K <sub>w</sub>	Hz	RPM	A	B	F1	H	H1	H2	H3	M1	M2	N1	N2	W1	W2		
125	100	3	50	1450	180	330	191	160	335	305	175	168	118	230	190	826	521	88	0,8
	112	4	60	1750												861	95	0,8	
150	112	4	50	1450	200	390	205	190	375	345	215	229	160	280	240	928	535	100	0,8
	132 S	5,5	60	1750												965		132	0,8
250	132 S	5,5	50	1450	200	390	219	190	375	345	215	229	160	280	240	991	598	168	1,2
	132 M	7,5	60	1750												1028		178	1,2
320	132 M	7,5	50	1450	200	390	275	190	405	345	215	229	160	280	240	1133	704	185	1,4
	160 M	11	60	1750												1202		225	1,4
450	160 M	11	50	1450	200	390	312	190	405	345	215	229	160	280	240	1240	741	235	1,5
	160 L	15	60	1750												1284		250	1,5

\* Weight refers to AISI 316 pump.

FLANGES DN PN 10/16 (mm)				
VPL	DN	D2	D3	D4
125 - 150	40	110	150	18
250 - 320 - 450	80	145	190	

d	DRAIN CONNECTION	3/8" G.
dv	AUTOMATIC DRAIN VALVE CONNECTION	1/2" G.
Lr	LIQUID RING CONNECTION	1/2" G.



## VPL 125, 150, 250, 320, 450 SECTION AND PART LIST

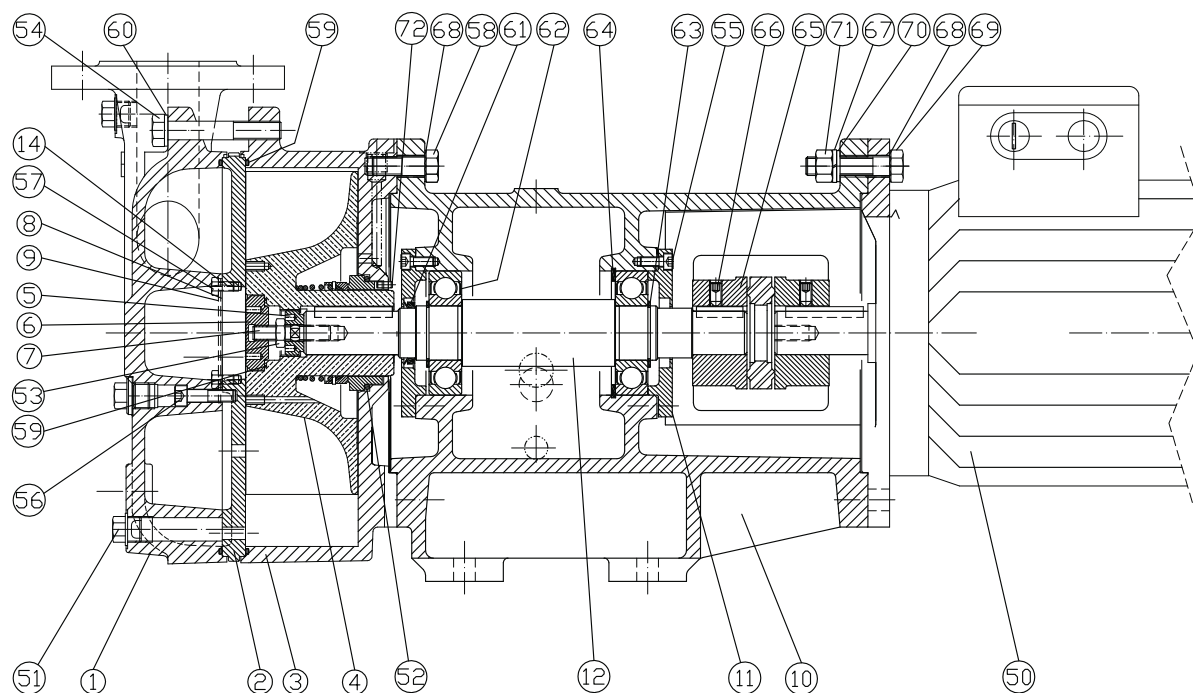

POS.	DESCRIPTION
1	END SHIELD
2	PORT PLATE
3	CASING
4	IMPELLER
5	SET COLLAR
6	COVER PLATE
7	STUD BOLT
8	VALVE
9	VALVE PLATE
10	PUMP BRACKET
11	BEARING COVER
12	SHAFT

POS.	DESCRIPTION
14	WASHER
50	MOTOR
51	LOCKING SCREW
52	MECHANICAL SEAL
53	NUT
54	SCREW
55	SCREW
56	SCREW
57	SCREW
58	SCREW
59	O-RING
60	O-RING

POS.	DESCRIPTION
61	VA - RING
62	BALL BEARING
63	RETAINING RING
64	RETAINING RING
65	ELASTIC COUPLING
66	SCREW
67	WASHER
68	WASHER
69	SCREW
70	WASHER
71	NUT
72	PIN

# VERTICAL PUMPS

## VERTICAL CENTRIFUGAL PUMPS

Vertical centrifugal pumps are suitable for installations with pump immersed directly in the tank.

GemmeCotti can supply the following models of vertical pumps:

### HV

- Thermoplastic pumps made in PP or PVDF.
- Capacity up to 40 m<sup>3</sup>/h.
- Head up to 22 m.
- Monobloc pump with semi open-impeller.
- Suitable for high corrosive liquids with solids in suspension.
- Maximum length 1000 mm.

### HVL

- Thermoplastic pumps made in PP or PVDF.
- Capacity up to 57 m<sup>3</sup>/h.
- Head up to 39 m.
- Centrifugal pump with coupling and semi open-impeller.
- Suitable for high corrosive liquids with solids in suspension.
- Maximum column length 2000 mm.

### PVA

- Vertical centrifugal cantilever pumps.
- Made in AISI316.
- Capacity up to 24 m<sup>3</sup>/h.
- Head up to 26 m.
- Especially designed for the production of PCBs.

### HTM-V

- Vertical magnetic drive pumps.
- Thermoplastic pumps made in PP or PVDF.
- Capacity up to 23 m<sup>3</sup>/h.
- Head up to 20 m.
- Column length: 320 mm.

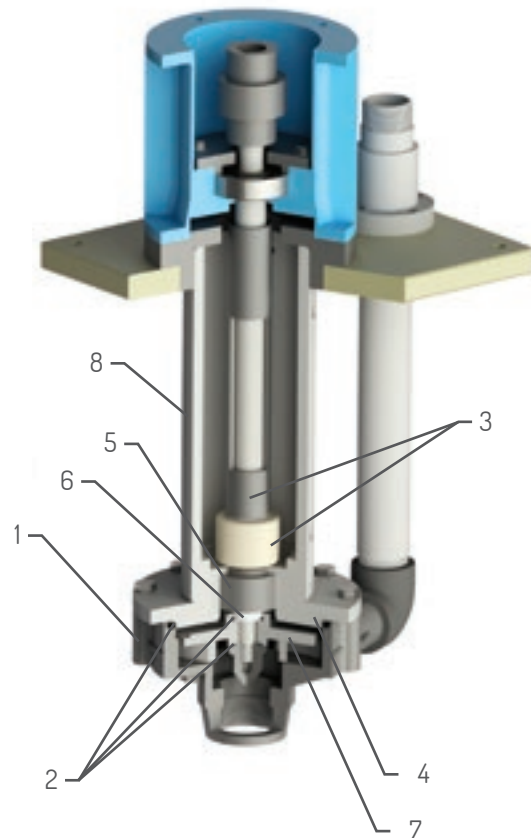

MATERIALS IN CONTACT WITH THE LIQUID

PART NUMBER - DESCRIPTION	VERTICAL PUMPS	
	HV	HVL
1 - PUMP HEAD	PP OR PVDF	PP OR PVDF
2 - O-RING	EPDM OR VITON	EPDM OR VITON
3-SHAFT COVERING/GUIDE SHAFT COV.	PP	PP
4- COVER	PP OR PVDF	PP OR PVDF
5- BUSHING	PTFEC	PTFEC
6- WEAR BUSHING	Al <sub>2</sub> O <sub>3</sub>	Al <sub>2</sub> O <sub>3</sub>
7- IMPELLER	PP OR PVDF	PP OR PVDF
8- COLUMN	PP OR PVDF	PP OR PVDF

## VERTICAL CENTRIFUGAL PUMPS



### FEATURES

- Centrifugal monobloc pump.
- Materials available: PP, PVDF.
- Max flow: 40 m<sup>3</sup>/h; Max head: 22 m.
- Temperature: PP: max 70°C; PVDF: max 90°C.
- Suitable for high corrosive liquids containing solids in suspension.
- Length of the column: from 500 to 1000 mm.

### STANDARD

- Threaded In and Out connections.

### OPTIONAL

- Dry-running protection.
- Flanges available.
- Suction strainer.

## PERFORMANCE CURVES 50HZ - 2900 RPM

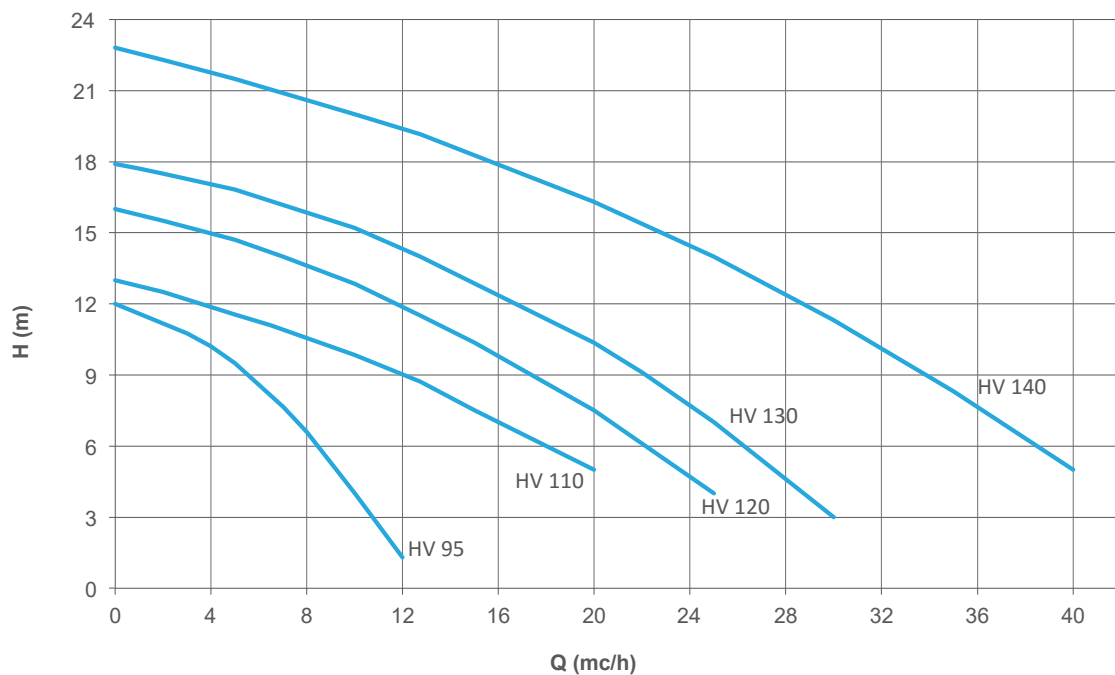

# VERTICAL CENTRIFUGAL PUMPS

## HV TECHNICAL DATA

PUMP SIZE	MATERIAL	Ø MAX		H MAX		SUCTION CONNECTION	DISCHARGE CONNECTION	COLUMN LENGTHS (mm)	SUITABLE MOTOR POWER (KW) - 2900 rpm	MOTOR FLANGE AND FRAME
		50HZ (m <sup>3</sup> /h)	60HZ (usgpm)	50HZ (m/c)	60HZ (ft)					
HV 95	PP- PVDF	12	62	12	55	2" FEMALE	1 1/2" MALE	from 500 to 1000	0,75	80 2A - B5
HV 110	PP- PVDF	20	105	13	60	2" FEMALE	1 1/2" MALE	from 500 to 1000	1,1	80 2B - B5
HV 120	PP- PVDF	25	132	16	75	2" FEMALE	1 1/2" MALE	from 500 to 1000	1,5	90 S - B5
HV 130	PP- PVDF	30	158	18	90	2" FEMALE	1 1/2" MALE	from 500 to 1000	2,2	90 L - B5
HV 140	PP- PVDF	40	210	22	105	2" FEMALE	1 1/2" MALE	from 500 to 1000	3	100 L - B5

## HV 95 - 110 - 120 - 130 - 140 PP/PVDF DIMENSIONS

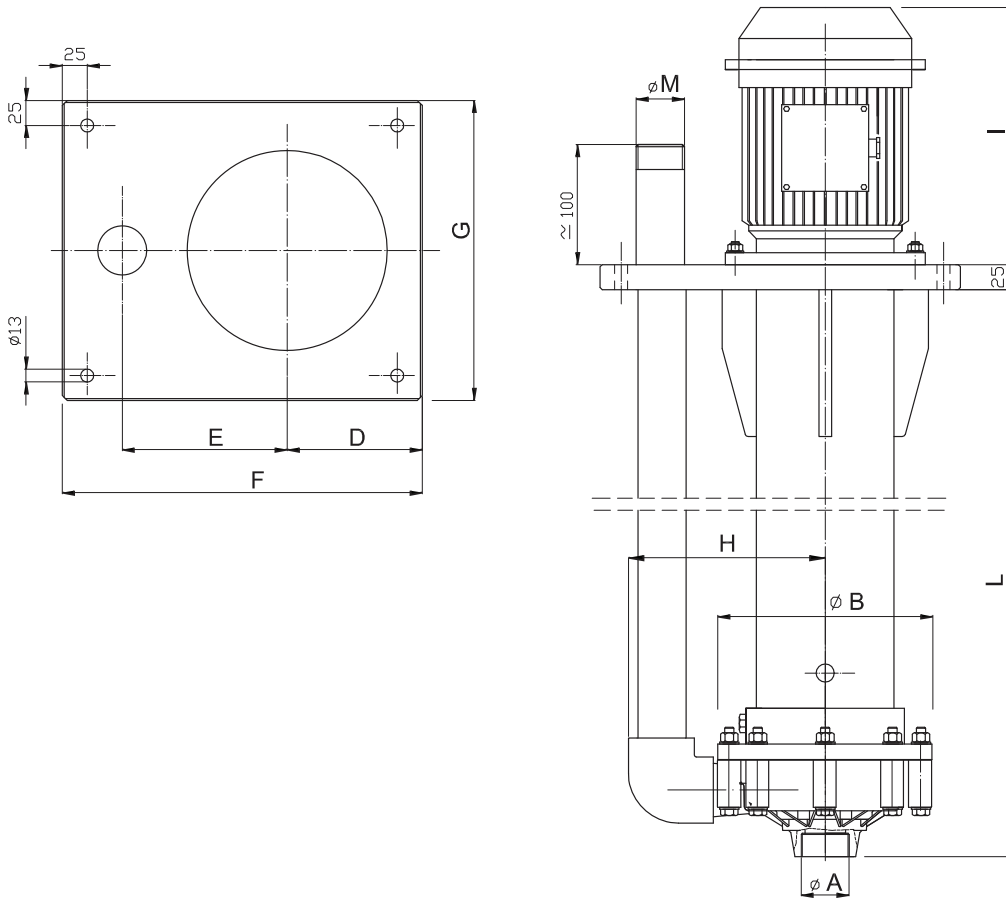

PUMP TYPE	MOTOR B5	KW	DIMENSIONS - mm -									
			ØA	ØM	ØB	D	E	F	G	H	I	L
HV 95	G 80	0,75	2" F	1 1/2" M	215	135	165	360	300	196	215	On request from 500 to 1000 mm
HV 110	G 80	1,1									230	
HV 120	G 90 S	1,5									255	
HV 130	G 90 L	2,2									280	
HV 140	G 100	3									315	

## VERTICAL CENTRIFUGAL PUMPS



### FEATURES

- Centrifugal pump with coupling.
- Materials available: PP, PVDF.
- Max flow: 57 m<sup>3</sup>/h; Max head: 39 m.
- Temperature: PP: max 70°C; - PVDF: max 90°C.
- Suitable for high corrosive liquids containing solids in suspension.
- Length of the column: from 500 to 2000 mm.

### STANDARD

- Threaded In and Out connections.

### OPTIONAL

- Dry-running protection.
- Flanges available.
- Suction strainer.

## PERFORMANCE CURVES 50HZ - 2900 RPM

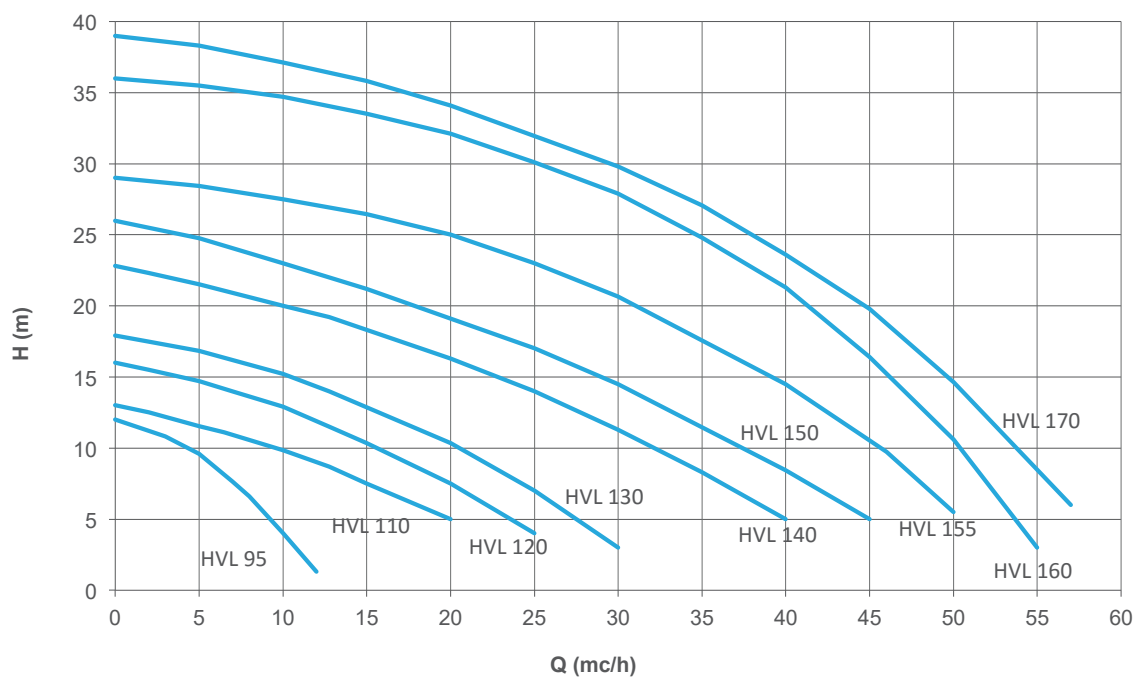

# VERTICAL CENTRIFUGAL PUMPS

## HVL TECHNICAL DATA

PUMP SIZE	MATERIAL	Q MAX		H MAX		SUCTION CONNECTION	DISCHARGE CONNECTION	COLUMN LENGTHS (mm)	SUITABLE MOTOR POWER (KW) - 2900 rpm	MOTOR FLANGE AND FRAME
		50HZ (m <sup>3</sup> /h)	60HZ (usgpm)	50HZ (m/c)	60HZ (ft)					
HVL 95	PP- PVDF	12	62	12	55	2" FEMALE	1 1/2" MALE	from 500 to 2000	0,75	80 2A - B5
HVL 110	PP- PVDF	20	105	13	60	2" FEMALE	1 1/2" MALE	from 500 to 2000	1,1	80 2B - B5
HVL 120	PP- PVDF	25	132	16	75	2" FEMALE	1 1/2" MALE	from 500 to 2000	1,5	90 S - B5
HVL 130	PP- PVDF	30	158	18	90	2" FEMALE	1 1/2" MALE	from 500 to 2000	2,2	90 L - B5
HVL 140	PP- PVDF	40	210	22	105	2" FEMALE	1 1/2" MALE	from 500 to 2000	3	100 L - B5
HVL 150	PP- PVDF	45	240	26	120	3" MALE	2 1/2" MALE	from 500 to 2000	5,5	132 S2A - B5
HVL 155	PP- PVDF	50	265	29	140	3" MALE	2 1/2" MALE	from 500 to 2000	5,5	132 S2A - B5
HVL 160	PP- PVDF	55	290	36	175	3" MALE	2 1/2" MALE	from 500 to 2000	7,5	132 S - B5
HVL 170	PP- PVDF	57	300	39	180	3" MALE	2 1/2" MALE	from 500 to 2000	9	132 S - B5

## HVL 95 - 110 - 120 - 130 - 140 - 150 - 155 - 160 - 170 PP/PVDF DIMENSIONS

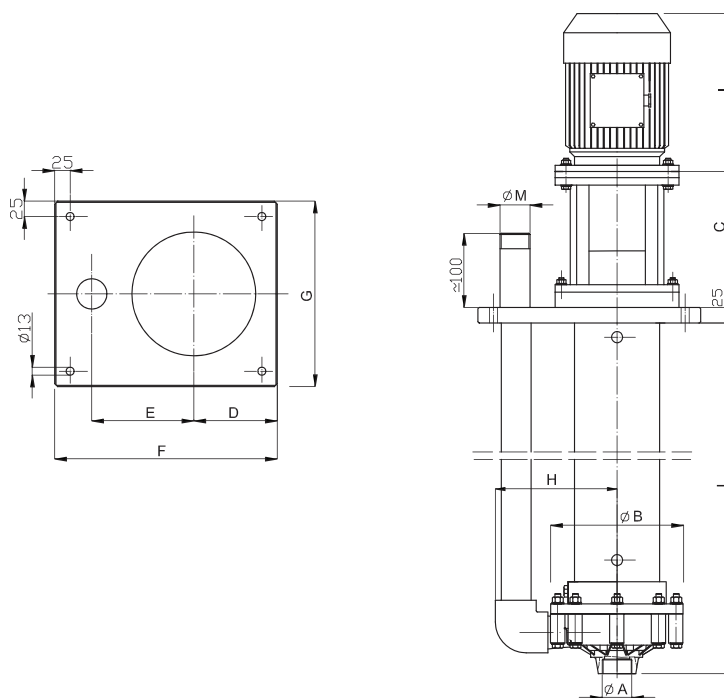

PUMP TYPE	MOTOR B5	KW	DIMENSIONS - mm -										
			ØA	ØM	ØB	C	D	E	F	G	H	I	L
HVL 95	G 80	0,75	2" F	1 1/2" M	215	210	135	165	360	300	196	215	On request from 500 to 2000 mm
HVL 110	G 80	1,1				210	135	165	360	300		230	
HVL 120	G 90 S	1,5				220	135	165	360	300		255	
HVL 130	G 90 L	2,2				220	135	165	360	300		280	
HVL 140	G 100	3				230	135	165	360	300		315	
HVL 150	G 132 SA	5,5	3" M	2 1/2" M	275	250	170	215	480	380	260	380	
HVL 155	G 132 SA	5,5										420	
HVL 160	G 132 SB	7,5										420	
HVL 170	G 132 SB	9										420	
												420	

## VERTICAL MAG DRIVE CENTRIFUGAL PUMPS



### MAIN FEATURES

Vertical mag drive centrifugal pumps series HTM-V are made of thermoplastic materials (Polypropylene and PVDF) and are suitable to handle chemicals and corrosive liquids. This kind of pump has been designed for a vertical submerged installation, providing high reliability for intank and sump applications. HTM-V are seal-less magnetic drive pumps without any kind of labyrinth or mechanical seal. The column of the pump is hermetically sealed and it allows complete isolation of the motor, the extension shaft and external magnet of the pump from the process liquid.

- Materials available: PP /PVDF.
- Materials in contact with the liquid: casing and impeller: PP/PVDF; o-ring: EPDM (standard for PP pumps); VITON (standard for PVDF pumps); shaft: Al2O3 99,7%; bushing: PTFEC.
- Max flow: 22 m<sup>3</sup>/h. Max head 20 mlc.
- Temperature: PP: max 70°C - PVDF: max 90°C.
- Compact design, column length 320mm.

### OPTIONAL:

- Dry running protection.
- Also available with bracket suitable for NEMA motors.

## PERFORMANCE CURVES 50HZ - 2900 RPM

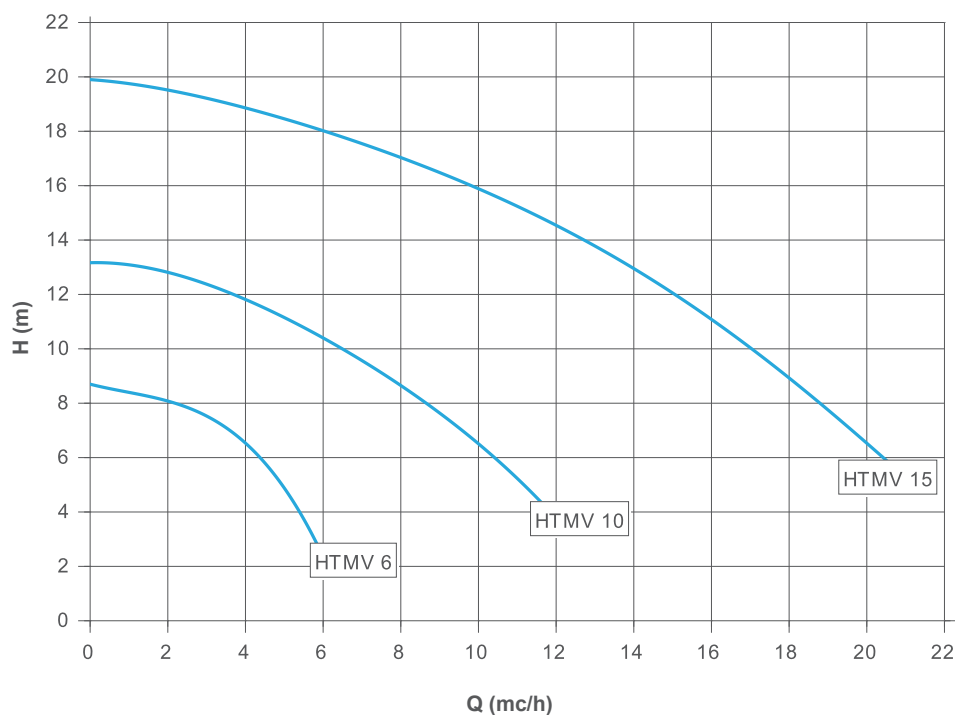

## CENTRIFUGAL VERTICAL CANTILEVER PUMPS



### FEATURES

- Materials available: AISI 316 or Titanium.
- Max flow: 24 m<sup>3</sup>/h. Max head: 26 m.
- Fume labyrinth seal. A combined system of labyrinth, rings and PTFE lip seal guarantees tightness against gas and vapours.
- Impeller with low axial thrust.
- Suitable for corrosive liquids containing solids.
- Especially designed for use in the production of printed circuit boards (PCB).  
AISI 316 version is suitable for potassium permanganate applications at 90°C.  
Titanium version is suitable for "Black Oxide".
- Two different types available: PVA 1 for tank transfer and PVA 2 used as a boosting pump. PVA 2 model should be installed in the same tank where PVA 1. This provides a tight system which prevents any leaks.

### PERFORMANCE CURVES 50HZ - 2900 RPM

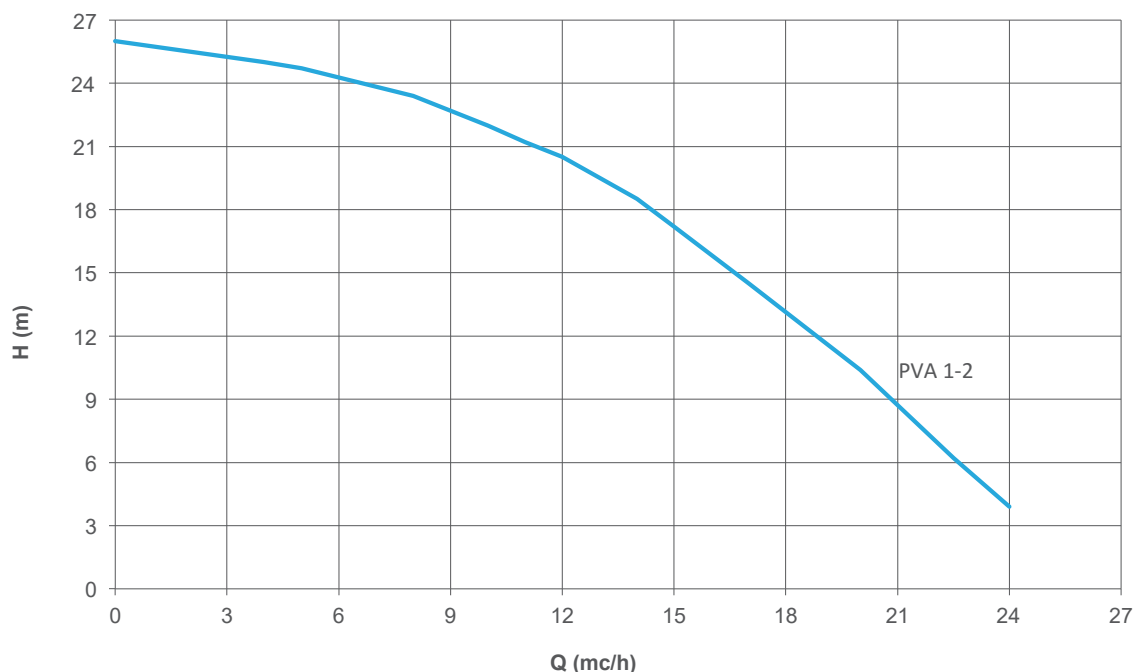



## PVA 1 DIMENSIONS

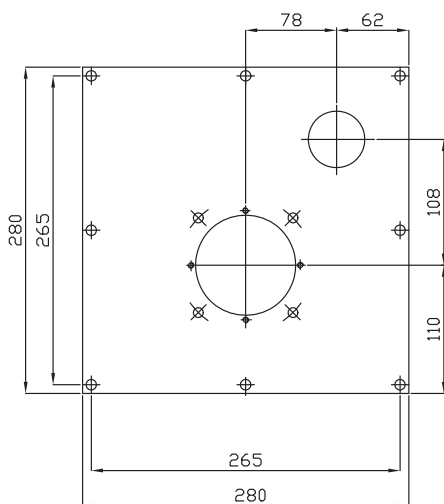
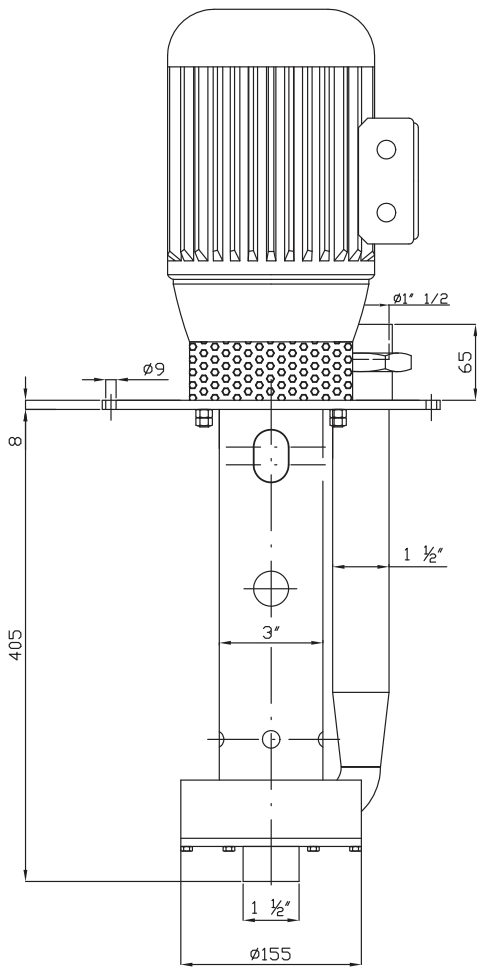

## PVA 2 DIMENSIONS

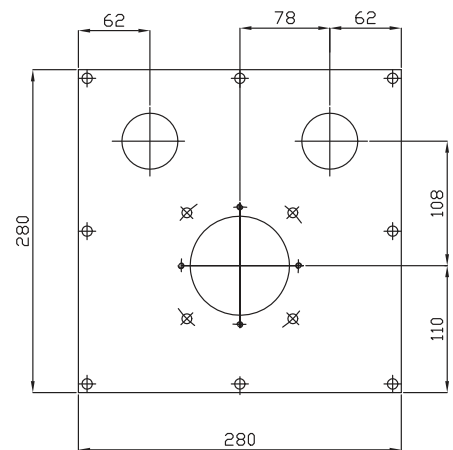
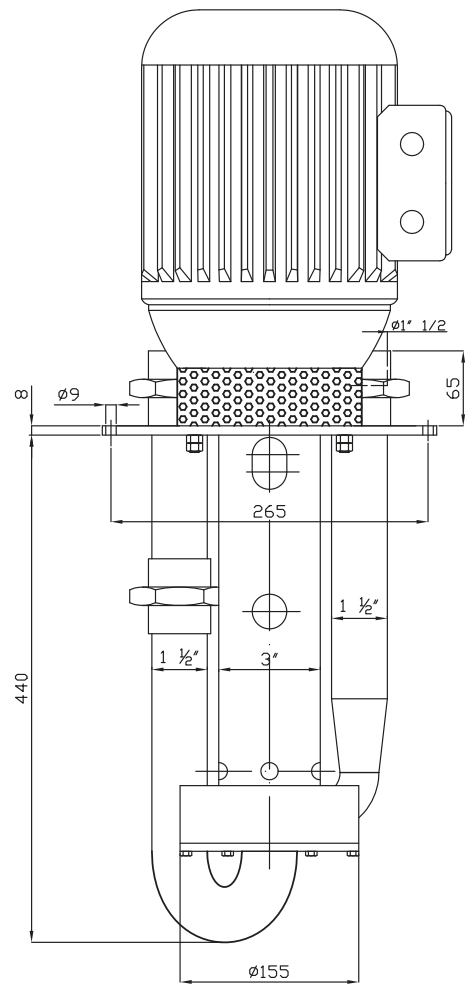

# ATEX PUMPS



For pumping applications in potentially explosive atmospheres GemmeCotti offers ATEX certified pumps suitable for zone 1 II 2G c Tx and zone 2 II 3G c Tx.

## The ATEX pumps available are:

Pumps model EM-C / EM-T / EM-P in PP or PVDF - only for ATEX zone 2 (See pumps model HTM PP/PVDF page 12, HTT page 26 and HPP/HPF page 34)

All our ATEX pumps comply with the technical and safety requirements of ATEX directive 2014/34/EU.

Pump model EM-C in AISI316 - for ATEX zone 1 and 2 (See pump model HTM SS316 page 20)



Pump model EM-T in AISI 316 - for ATEX zone 1 and 2 (See pump model HTA page 30)

Pump model EM-P in AISI 316 for ATEX zone 1 and 2 (See pump model HTP page 36)



## DRY-RUNNING PROTECTION

The installation of W 01 Emirel prevents expensive damage to pumps because it avoids the dry-running working, the closed discharge and the blocked suction. We recommend the use of this instrument to unload tank truck or every other application when it's not certain if the liquid is constantly present in the pipes. This device checks constantly the active power of the motor, that is the medium value of the instantaneous power absorbed by the pump, through the reception of information about the voltage and about the voltage variations. Through a set point and a timer, which are adjustable, it's possible to set the minimum power and the triggering time of the device. If the power goes under the established value, the pump stops and the device must be switched on again manually.



In case of continuous intervention on the apparatus, check the presence of liquid and/or the correct functioning of the plant to find the cause of working of the device.

## FLANGES

GemmeCotti pumps are usually supplied with threaded connections. Upon request we can also supply DIN or ANSI flanges for thermoplastic pumps (flat stub + free flange) and welded DIN or ANSI flanges for AISI316 pumps.



# ACCESSORIES

## BASEPLATES

### MAIN FEATURES

- Baseplates suitable for pumps complete with motors  
B3/B5;
- Allow a steady horizontal position of the pumps;
- Fast and easy installation thanks to predrilled holes placed on the surface and designed for the different motor sizes.

### MATERIAL

- PP

### DIMENSION AVAILABLE

Available in 3 different dimensions:

- BASEPLATE TYPE "A" suitable for:  
IEC motors B3/B5 from size 56 to size 71
- BASEPLATE TYPE "B" suitable for:  
IEC motors from size 80 to size 90 and  
NEMA motors 56TC and 145T.
- BASEPLATE TYPE "C" suitable for:  
IEC motors from size 100 to size 112 and  
NEMA motors 184T.



## DIMENSIONS

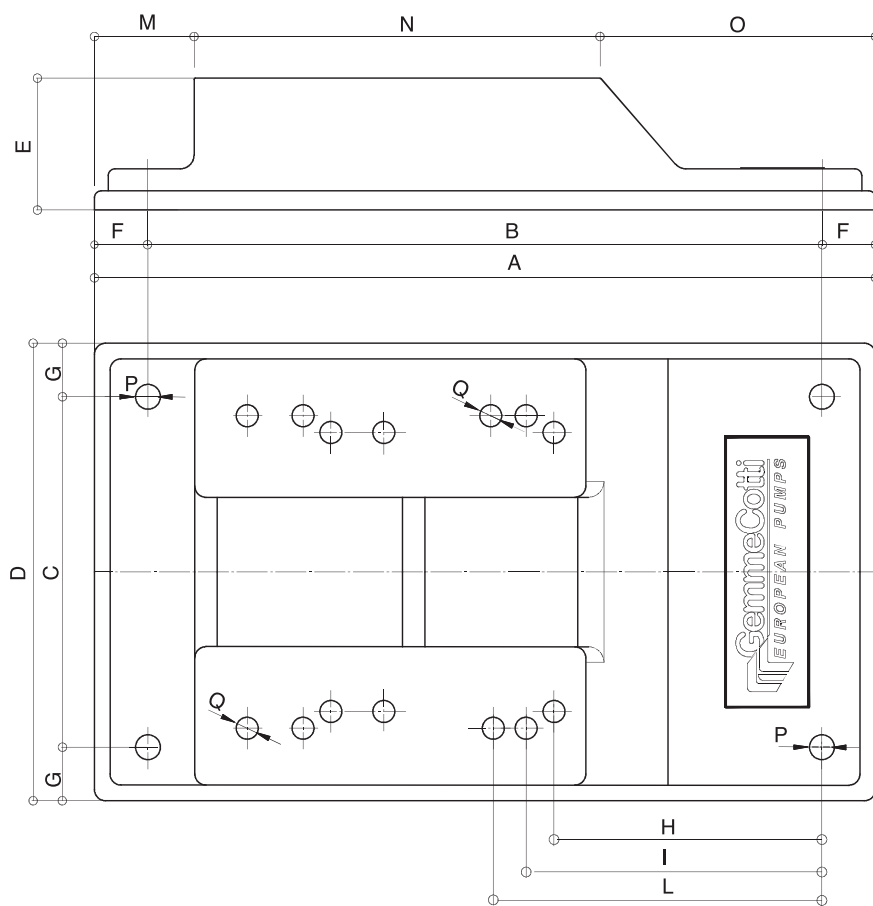

TYPE	MOTOR	DIMENSIONS - mm -														
		A	B	C	D	E	F	G	H	I	L	M	N	O	P	Q
A	IEC-GR. 56															
	IEC-GR. 63	280	244	130	160	48	18	15	94	102	112	29	151	100	8	8
	IEC-GR. 71															
B	IEC-GR. 80															
	IEC-GR. 90	350	302	157	205	60	24	24	120	132	-	45	175	130	12	11
	NEMA-GR. 56TC															
C	NEMA-GR. 145T															
	IEC-GR. 100	400	352	202	250	60	24	24	140	156	-	45	210	145	12	12
	IEC-GR. 112															
	NEMA-GR. 184T															

# CHEMICAL COMPATIBILITY GUIDE

Legend: **A**= Very good | **B**= Good | **C**= Poor, not recommended | **D**= Very poor, not recommended | **1**= Good until 22°C (72°F) | **2**= Good until 48°C (120°F)

CHEMICAL	PUMP MATERIALS			O-RINGS MATERIALS		
	PP	PVDF	AISI 316	EPDM	Viton	PTFE
ACETIC ACID	B	C	B	A	B	A
ACETIC ACID 20%	A	A	A	A	B	A
ACETIC ACID 80%	A	C	B	A	B	A
ACETIC ACID, GLACIAL	A1	A1	A	B	D	A
ACETONE	A	D	A	A	D	A
ALCOHOLS: ETHYL	A	A	A	A	A	A
ALCOHOLS: ISOPROPYL	A2	A	B	A	A	A2
ALCOHOLS: METHYL	A2	A	A	A	C	A
ALCOHOLS: PROPYL	A	A2	A	A	A	A
ALUMINIUM SULFATE	A	A	B2	A	A	A
AMINES	B2	-	A	B	D	A2
AMMONIA, LIQUID	A2	A	A2	A	D	A
CHLORINE, ANHYDROUS LIQUID	D	A1	C	B	A	A
CHLOROFORM	C1	A	A	D	A	A1
CHROMIC ACID < 50%	D	A2	B2	B	A	A
COPPER CHLORIDE	A	A	D	A	A	A
COPPER SULFATE > 5%	A	A	B	A	A	A
DETERGENTS	A	A	A1	A	A	A
DIESEL FUEL	A1	A	A1	D	A	A
ETHER	D	B1	A	C	C	A
ETHYLENE GLYCOL	A	A	B	A	A	A
ETHYL ACETATE	A1	D	B	B	D	A
FERRIC CHLORIDE	A	A	D	A	A	A
FORMALDEHYDE 100%	C	A	A	A	D	A
FUEL	A1	A	A1	D	A	B
FUEL OILS	A	B	A	D	A	B
GASOLINE (HIGH - AROMATIC)	A	A	A	D	A	A
GLUCOSE	A	A	A	A	A	A
HYDRAULIC OIL (PETRO)	D	A	A	D	A	A
HYDROCHLORIC ACID < 33%	A2	A	D	A2	A	A
HYDROFLUORIC ACID 50%	A	A	D	D	B	A
HYDROFLUORIC ACID 100%	C1	A	B1	D	B	A
HYDROGEN PEROXIDE 10%	A	A	B	A	A	A
HYDROGEN PEROXIDE 30%	B1	A	B	B	A	A
KEROSENE	A	B	A	D	A	A

All the information in this chart is only approximate and should only be used for an initial choice of the type of materials best suited for the customers' pumps. The data comes from various highly reliable sources. Despite this, GemmeCotti itself did not carry out the relative tests, and is not responsible for the preciseness of the data. Therefore, GemmeCotti has no responsibility for possible malfunctions or damage of any type caused by the incorrect selection of construction materials and/or of the incorrect choice of pump size if it is not made by GemmeCotti itself after having received all suitable information regarding the application and the characteristics of the pumped liquid.

CHEMICAL	PUMP MATERIALS			O-RINGS MATERIALS		
	PP	PVDF	AISI 316	EPDM	Viton	PTFE
LACQUER THINNERS	D	-	A	D	D	A
MOTOR OIL	A1	B	A2	D	-	A
NAPHTHA	B	A	A	D	A	B
NICKEL CHLORIDE	A	A	C	A1	A	A
NITRIC ACID < 50%	D	A	A1	D	A	A
OIL: HYDRAULIC OIL (SYNTHETIC)	D	A	A	A	A	A
OLIVE OIL	A	-	A	D	A	A1
PHENOL (CARBOLIC ACID)	B	A1	B	B	A	A
POTASSIUM PERMANGANATE	A1	A	B	A	A	A
PHOSPHORIC ACID < 40%	A	A	C	A	A	A
PHOSPHORIC ACID > 40%	A	A	D	A	A	A
PHOTOGRAPHIC DEVELOPER	A	-	A	B	A	A
ROSINS	A2	-	A1	-	A	A
SALT BRINE	A	A	A2	A	A2	A2
SEA WATER	A	A	C	A2	A	A
SOAP SOLUTIONS	A	A1	A1	A	A	A
SODIUM BICARBONATE	A	A	A1	A2	A	A
SODIUM BISULFITE	A	A	B1	A2	A	A
SODIUM CARBONATE	A	A	A	A2	A	A
SODIUM CHLORIDE	A	A	B	A	A	A
SODIUM HYDROXIDE (10%)	A	C	-	A	C	-
SODIUM HYDROXIDE (40%)	A	C	-	A	C	-
SODIUM HYDROXIDE (50%)	A	C	B1	A	D	A
SODIUM HYPOCHLORITE (100%)	C	A	C	B1	A1	A
SODIUM HYPOCHLORITE 12,5%	C	A	C	A	A	A
SULFURIC ACID (10-75%)	A1	A	D	B2	A2	A
SULFURIC ACID (75-100%)	C1	A	D	B1	A1	A
SULFURIC ACID 100%	D	D	A	D	A	A
TIN SALTS	A	A	D	B	A	A
TOLUENE (TOLUOL)	C1	A1	A	D	C	A
UREA	A	A	B	A	A	A
WATER, ACID, MINE	A	A	B	A	A	A
WATER, DISTILLED	A	A	A	A	A	A
ZINC CHLORIDE	A	A	B	A	A	A



**GEMMECOTTI SRL**

Via A. Volta 85/A  
20816 Ceriano Laghetto MB  
ITALY  
EUROPEAN UNION

Ph: +39 02.96460406  
Fax: +39 02.96469114

info@gemmecotti.com  
[www.gemmecotti.com](http://www.gemmecotti.com)

